

Paul M. Rady Department of Mechanical Engineering

Graduate and Elective Courses

- » Please scroll through this document to view the department's technical electives.
- » Slides two, three and four organize the ME technical electives by focus area. Click each link to find the course description and which semester the course is typically offered.
- » Information about potential emphasis options for MS Thesis or MS Professional students is available on the [graduate program website](#).

Full List of Graduate and Elective Courses by Focus Area



Graduate Foundations

[MCEN 5020: Methods of Engineering Analysis](#)

[MCEN 5021: Intro to Fluid Dynamics](#)

[MCEN 5022: Classical Thermodynamics](#)

[MCEN 5023: Solid Mechanics](#)

[MCEN 5024: Materials Chemistry and Structures](#)

[MCEN 5042: Heat Transfer](#)

[MCEN 5044: Mechanical Behavior of Materials](#)

[MCEN 5208: Intro to Research \(PhD, MS Thesis\)](#)

[MCEN 5000: Sociotechnical Industry Skills \(MS Professional\)](#)



Materials

[MCEN 5024: Materials Chemistry and Structures](#)

[MCEN 5044: Mechanical Behavior of Materials](#)

[MCEN 4194/5194: Energy Conversion/Storage](#)

[MCEN 4228/5228: Nano Science/Engineering](#)

[MCEN 4228/5228: Thin Film Materials](#)

[MCEN 4228/5228: Mechanics of Biological Materials](#)

[MCEN 4292/5292: Materials/Devices in Medicine](#)

[MCEN 4298/5298: Intro to Polymers](#)

[MCEN 6184: Structures/Properties of Polymers](#)

[MCEN 6228: Self-Assembling Materials](#)



Mechanics of Materials

[MCEN 5023: Solid Mechanics](#)

[MCEN 5044: Mechanical Behavior of Materials](#)

[MCEN 4133/5133: Intro to Tissue Biomechanics](#)

[MCEN 5147: Mechanobiology](#)

[MCEN 4173/5173: Finite Element Analysis](#)

[MCEN 4174/5174: Failure of Eng. Materials](#)

[MCEN 4183/5183: Mech of Composite Materials](#)

[MCEN 4113/5113: Mechanics of Cancer](#)

[MCEN 4228/5228: Mechanics of Snow](#)

[MCEN 5153: Fracture Mechanics](#)

[MCEN 4293/5293: Mechanics of Soft Matter](#)

[MCEN 6228: Continuum Mechanics](#)



Full List of Graduate and Elective Courses by Focus Area



Thermo Fluid Sciences

[MCEN 5021: Fluid Dynamics](#)

[MCEN 5022: Classical Thermo](#)

[MCEN 5042: Heat Transfer](#)

[MCEN 4151/5151: Flow Visualization](#)

[MCEN 4152/5152: Intro to Combustion](#)

[MCEN 4228/5228: Thermofluids Lab](#)

[MCEN 4228/5228: Biofluids](#)

[MCEN 4228/5228 Thermal Systems Innovation](#)

[MCEN 4231/5231: Computational Fluid Dynamics](#)

[MCEN 4012/5012: Renewable Fuels, Fuel Cells, & ICE](#)

[MCEN 4228/5228: Fluid Mech in the Human Body](#)

[MCEN 4111/5111: Intro to Microfluidics](#)

[MCEN 6001: Reacting Flows](#)



Micro/Nanoscale

[MCEN 4228/5228: Biofluids](#)

[MCEN 4111/5111: Intro to Microfluidics](#)

[MCEN 4228/5228: Thin Film Materials](#)

[MCEN 4228/5228 Membrane Technologies](#)

[MCEN 4298/5298: Intro to Polymers](#)

[MCEN 4228/5228: Intro to Nanoscale Transport](#)

[MCEN 5228: Flexible Electronics](#)

[MCEN 5636: Micro-Electro-Mechanical Systems](#)

[MCEN 6184: Structures/Properties of Polymers](#)

[MCEN 6228: Self-Assembling Materials](#)

[MCEN 6228: Wetting, Adhesion, Friction](#)



Robotics and Systems Design

[MCEN 4115/5115: Mechatronics/Robotics 1](#)

[MCEN 4125/5125: Optimal Design](#)

[MCEN 4138/5138: Feedback Control](#)

[MCEN 4155/5155: Automated Mechanical Design](#)

[MCEN 4228/5228: Industrial Automation](#)

[MCEN 4228/5228: Vibrations](#)

[MCEN 4228/5228 Machine Learning in ME](#)

[MCEN 4228/5228: Biohybrid Robotics](#)

[MCEN 4195/5195: Bioinspired Robotics](#)

[MCEN 4157/5157: Modeling of Human Movement](#)

[MCEN 4228/5228: Mechatronics/Robotics 2](#)

[MCEN 5228: Advanced Dynamics](#)

[MCEN 5448: Linear Systems](#)

[MCEN 5636: Micro-Electro-Mechanical Systems](#)

[MCEN 6228: Robu](#)



Paul M. Rady

Mechanical Engineering

UNIVERSITY OF COLORADO BOULDER

Full List of Graduate and Elective Courses by Focus Area



Air Quality, Energy and the Environment

[MCEN 4032/5032: Sustainable Energy](#)
[MCEN 4131/5131: Air Pollution Control](#)
[MCEN 4135/5135: Wind Energy](#)
[MCEN 4141/5141: Indoor Air Pollution](#)
[MCEN 4152/5152: Intro to Combustion](#)
[MCEN 5161: Aerosols](#)
[MCEN 4194/5194: Energy Conversion/Storage](#)
[MCEN 4228/5228: Thermofluids Lab](#)
[MCEN 4231/5231: Computational Fluid Dynamics](#)
[MCEN 4012/5012: Renewable Fuels, Fuel Cells, and Internal Combustion Engines](#)
[MCEN 4228/5228: Climate Engineering](#)
[MCEN 4291/5291: PBL in Rural Schools](#)
[MCEN 4299/5299: Household Energy Systems](#)
[MCEN 6001: Reacting Flows](#)
[MCEN 6228: Kinetics of Chemical Systems](#)
[MCEN 7221: Turbulence](#)



Biomedical

[MCEN 4117/5117: Anatomy & Physiology](#)
[MCEN 4127/5127: Biomedical Ultrasound](#)
[MCEN 4133/5133: Intro to Tissue Biomechanics](#)
[MCEN 5147: Mechanobiology](#)
[MCEN 4171/5171: Biofluids on the Micro Scale](#)
[MCEN 4231/5231: Computational Fluid Dynamics](#)
[MCEN 4113/5113: Mechanics of Cancer](#)
[MCEN 4228/5228: Fluid Mech in the Human Body](#)
[MCEN 4228/5228: Surface Forces in Biology](#)
[MCEN 4228/5228: Advanced Biotransport](#)
[MCEN 4111/5111: Intro to Microfluidics](#)
[MCEN 4157/5157: Modeling of Human Movement](#)
[MCEN 4110/5110: Regenerative Bio/Tissue Repair](#)
[MCEN 4292/5292: Materials/Devices in Medicine](#)



Product Design and Manufacturing

[MCEN 5045: Design for Manufacturability](#)
[MCEN 5055: Advanced Product Design](#)
[MCEN 5065: Graduate Product Design 1](#)
[MCEN 5075: Graduate Product Design 2](#)
[MCEN 4115/5115: Mechatronics/Robotics 1](#)
[MCEN 4125/5125: Optimal Design](#)
[MCEN 4173/5173: Finite Element Analysis](#)
[MCEN 4155/5155: Automated Mechanical Design](#)
[MCEN 4215/5215: Design for Inclusion](#)
[MCEN 4228/5228: Industrial Automation](#)
[MCEN 4228/5228: Design of Beer](#)
[MCEN 4228/5228: Design Research Theory and Methods](#)
[MCEN 4036: Lean/Six Sigma Manufacturing](#)
[MCEN 4195/5195: Bioinspired Robotics](#)
[MCEN 4193/5193: Design of Coffee](#)
[MCEN 4238: Design for Community](#)
[MCEN 4279/5279: Aesthetics of Design](#)

MCEN 5020: Methods of Engineering Analysis

Career Areas

Engineering Foundation

Specializations

None

Prerequisites

None

Pre or Corequisites

None

Studies selected topics from linear algebra, ordinary differential equations and Fourier series. Assigns computer exercises. Correlates with analysis topics in other mechanical engineering graduate courses and emphasizes applications.

Course instructor(s):



Peter Hamlington



Daven Henze

Teaching schedule: Offered every fall semester.

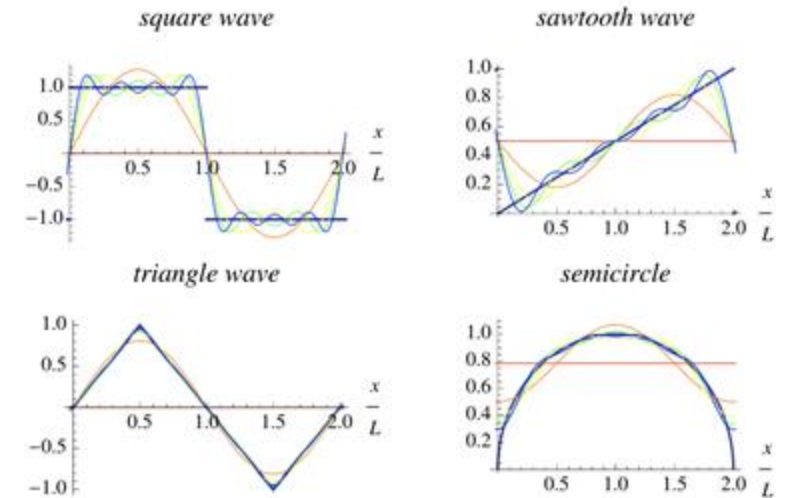

mathworld.wolfram.com/FourierSeries.html



MCEN 5021: Introduction to Fluid Dynamics

Career Areas

*Biomedical Engineering
Renewable Energy
Aviation/Space Exploration
Atmospheric Science*

Specializations

None

Prerequisites

None

Pre or Corequisites

MCEN 5020: MEA

Focuses on physical properties of gases and liquids, and kinematics of flow fields. Analyzes stress; viscous, heat-conducting Newtonian fluids; and capillary effects and surface-tension-driven flow. Other topics include vorticity and circulation, ideal fluid flow theory in two and three dimensions, Schwartz-Christoffel transformations, free streamline theory, and internal and free-surface waves.

Course instructor(s):



Xiaoyun Ding



Jean Hertzberg

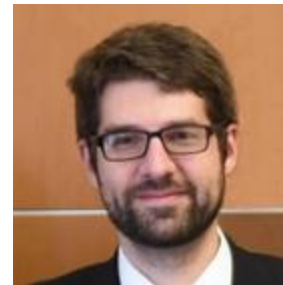

Jeremy Koch



Hana Kieger

Teaching schedule: Offered every fall semester.



MCEN 5022: Classical Thermodynamics

Career Areas

Power Generation
Renewable Energy
Aviation/Space Exploration
Transportation
Biomedical Engineering
Manufacturing

Specializations

None

Prerequisites

None

Pre or Corequisites

None

First and second laws of thermodynamics. Entropy and availability. Cycle analysis. Thermodynamic properties of pure substances and mixtures. Property relations. Chemical reactions and chemical availability. Energy systems analysis.

Thermodynamics

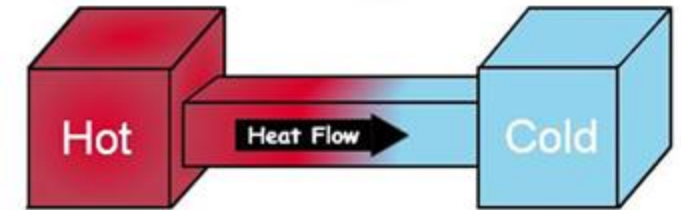

Course instructor(s):



Jeremy Koch



Nicole Labbe



Mike Walker

Teaching schedule: Offered every spring semester.



MCEN 5023: Solid Mechanics

Career Areas

Engineering Design
Structural Engineering
Failure Analysis
...and many more!

Specializations

None

Prerequisites

None

Pre or Corequisites

MCEN 5020: MEA

Introduces stress, strain and motion of a continuous system. Discusses material derivative; fundamental laws of mass, momentum, energy and entropy; constitutive equations and applications to elastic and plastic materials.

Course instructor(s):



Francois Barthelat

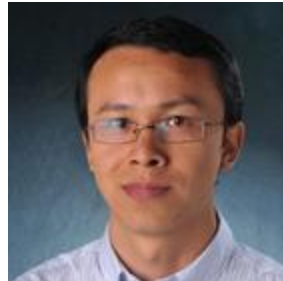

Jianliang Xiao

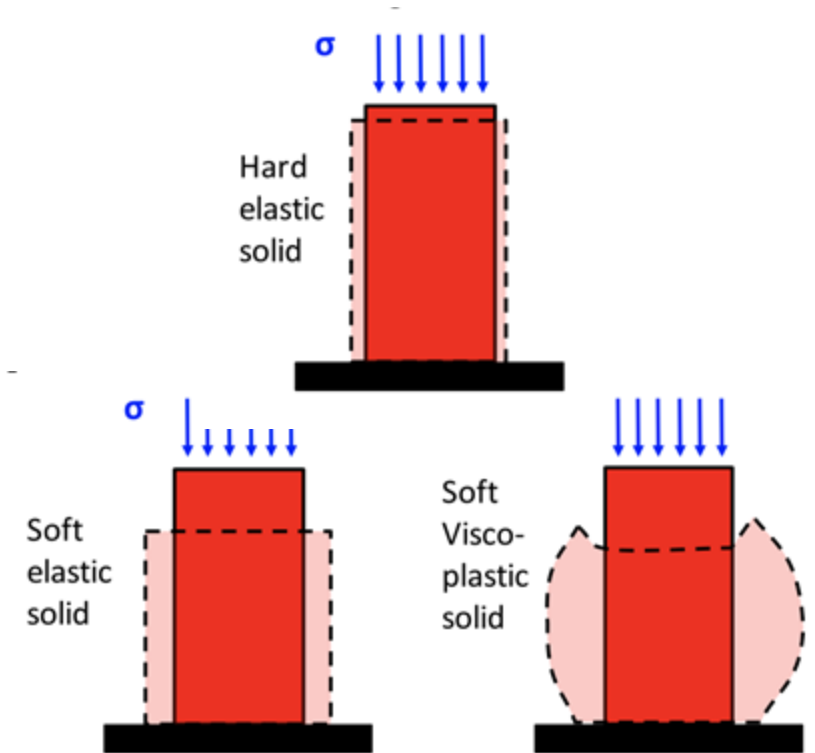

dnicolasespinoza.github.io/node16.html

Teaching schedule: Offered every fall semester.



MCEN 5024: Materials Chemistry and Structures

Career Areas

*Materials Science
Semiconductors
Energy Storage
Biomedical Applications
Manufacturing*

Specializations

None

Prerequisites

None

Pre or Corequisites

None

Provides graduate level students with a comprehensive overview of the chemistry and structure of material systems, with a focus on chemical bonding, the resulting material structures and their properties. Course topics include: bonding in solids, crystalline and amorphous states, basic group theory, diffraction, metals and alloys, ceramics, and an intro to materials characterization.

Course instructor(s):



Yifu Ding



Se-Hee Lee

Teaching schedule: Offered every spring semester.

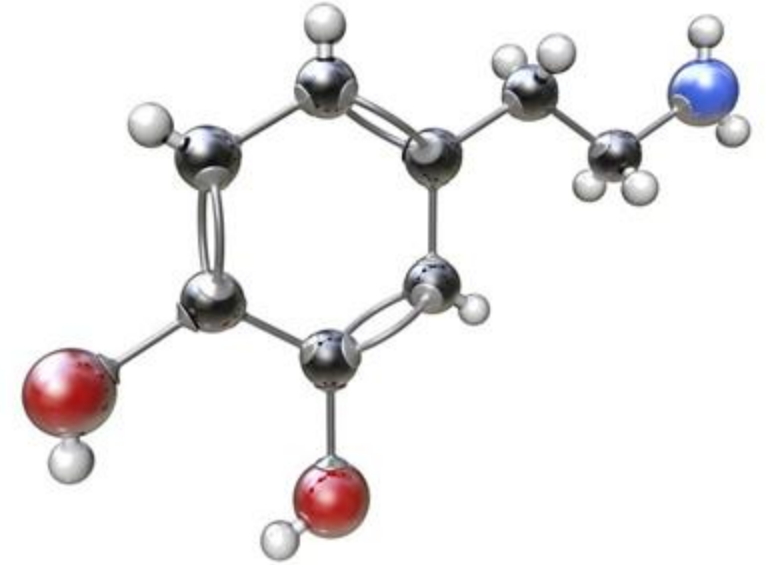

www.thoughtco.com/definition-of-bonds-in-chemistry-604392



MCEN 4032/5032: Sustainable Energy

Career Areas

Energy Efficiency
Renewable Energy
Environmental Policy

Specializations

BS Environmental Option
BS Energy Minor

Prerequisites

MCEN 3012: Thermo
MCEN 3021: Fluids

Pre or Corequisites

MCEN 3022: Heat Transfer

Examines sustainability of our current energy systems, including transportation, using environmental and economic indicators. Uses systems analysis that addresses energy supply and demand. Explores the science and technology as well as environmental and economic feasibility of efficiency measures and renewable energy technologies. Additional emphasis is given to the global nature of the challenges and the potential for locally optimal solutions.

Course instructor(s):



Mike Walker



Chuck Kutscher

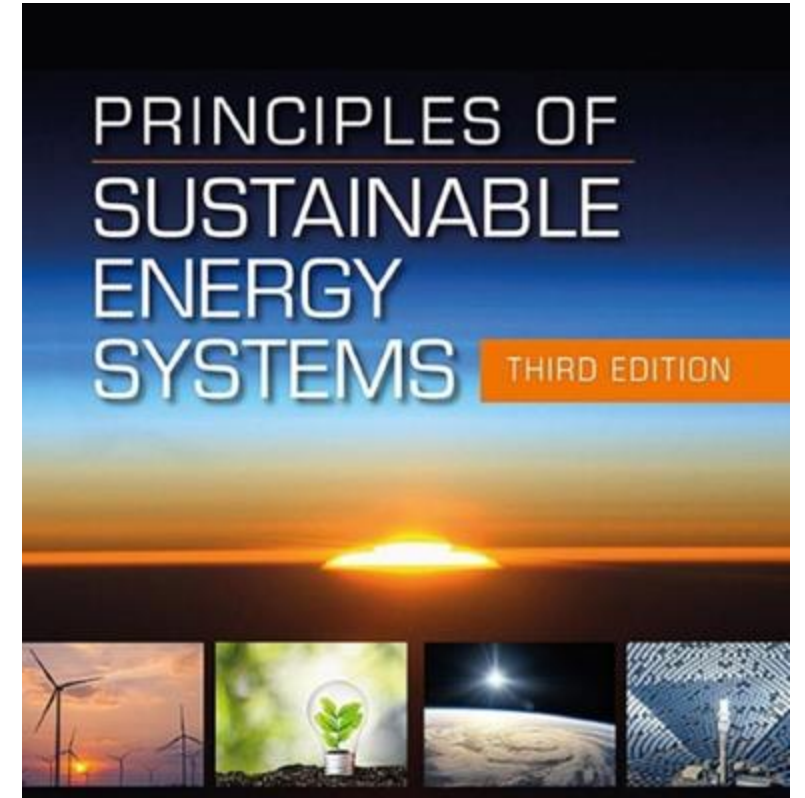

Teaching schedule: Offered every fall semester.



MCEN 5042: Heat Transfer

Career Areas

Power Generation
Aviation/Space Exploration
Transportation
Biomedical Engineering
Manufacturing

Specializations

None

Prerequisites

None

Pre or Corequisites

None

Studies development of equations governing transport of heat by conduction, convection, and radiation, and their solution. Includes analytical and numerical solution of initial and boundary value problems representative of heat conduction in solids. Describes heat transfer in free and forced convection, including laminar and turbulent flow. Also involves radiation properties of solids, liquids, and gases and transport of heat by radiation.

Course instructor(s):



Longji Cui



Jeff Knutsen



Nathalie Vriend

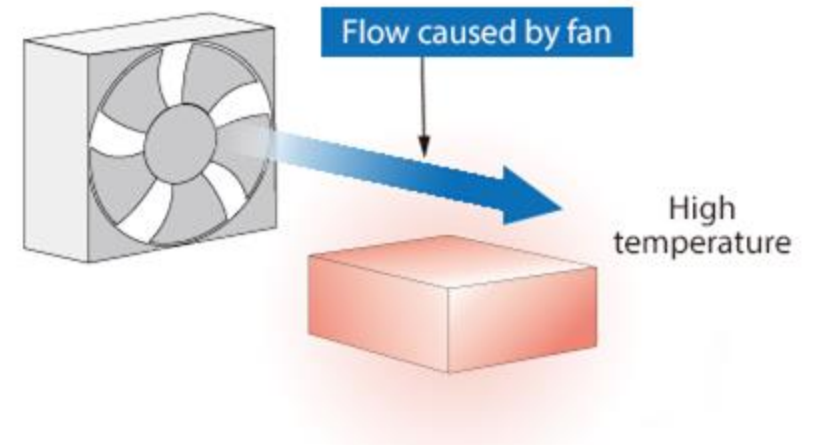

www.cradle-cfd.com/technology/glossary/ja_F/detail0053.html

Teaching schedule: Offered every spring semester.

MCEN 5044: Mechanical Behavior of Materials

Career Areas

Materials Science
Mechanics of Materials

Specializations

None

Prerequisites

None

Pre or Corequisites

None

Models are derived that link fundamental properties of materials at these successive length scales into analytical expressions for guiding and interpreting laboratory data. The course is divided into four distinct sections: elastic properties, plasticity, fracture and high temperature phenomena. Each topic is separated by its own exam, with each contributing approximately equally to the final grade. The course will be useful to students, researchers and practitioners.

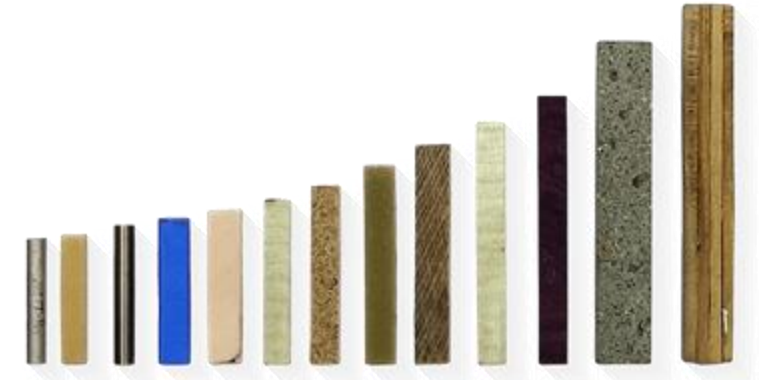

www.sonelastic.com/en/

Course instructor(s):



Rishi Raj

Teaching schedule: Generally offered spring semester. Availability may vary based on instructor schedule.

MCEN 5045: Design for Manufacturability

Career Areas

Product Design

Manufacturing

Project Management

Specializations

Graduate Design Emphasis

Prerequisites

None

Pre or Corequisites

None

Topics include general design guidelines for manufacturability; aspects of manufacturing processes that affect design decisions; design rules to maximize manufacturability; economic considerations; value engineering and design for assembly. Presents case studies of successful products exhibiting DFMA principles.

Course instructor(s):



Dan Riffell

Teaching schedule: Generally offered both fall and spring semester.

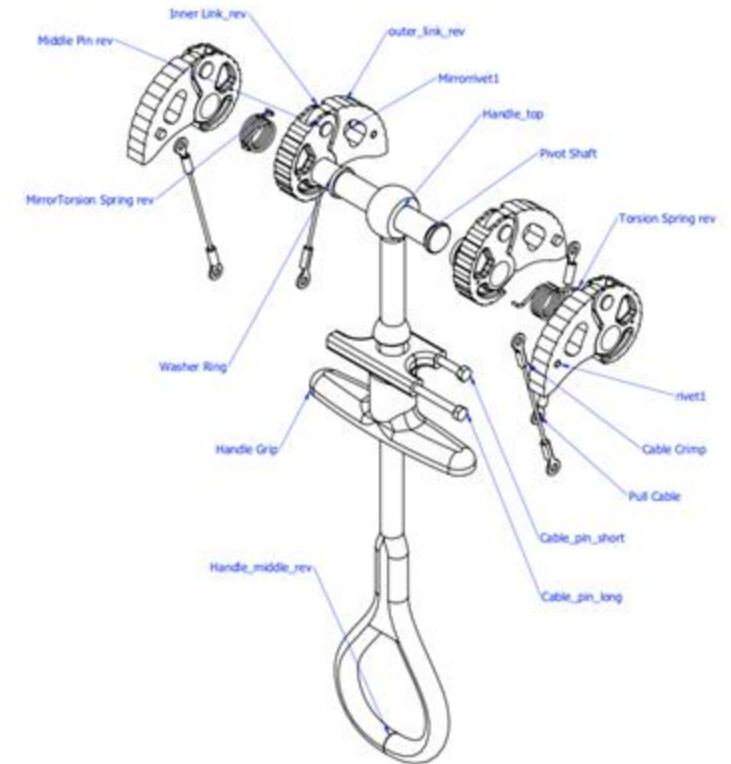

MCEN 5055: Advanced Product Design

Career Areas

Product Design

Specializations

Graduate Design Emphasis

Prerequisites

None

Pre or Corequisites

*MCEN 4045: Senior Design
Application Process*

Introduces the processes and methods for designing products. Course content includes: need finding and need specification, ideation and idea selection, design thinking, user-centered design, human factors, sketching, prototyping, user feedback, design communication, design for manufacturing, materials selection, and intellectual property. Teams of 3-4 students will design and build a novel product throughout the semester.

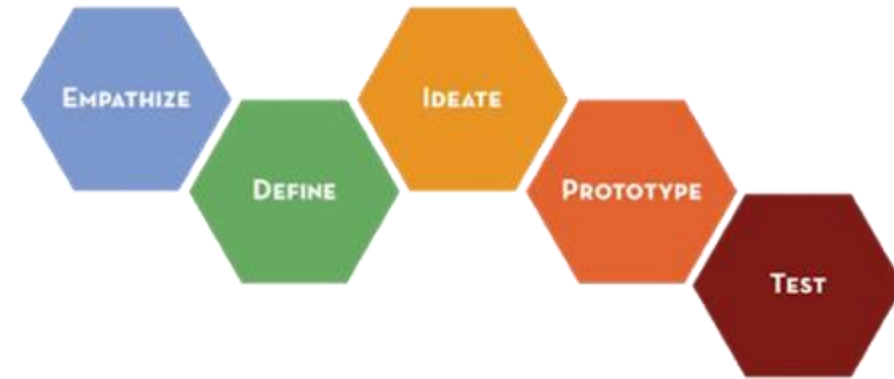

Course instructor(s):



Janet Tsai



Greg Rieker

James Harper

Teaching schedule: Generally offered both fall and spring semester.



MCEN 5065: Graduate Product Design 1

Career Areas

Product Design

Specializations

Graduate Design Emphasis

Prerequisites

MCEN 5055: APD

Pre or Corequisites

None

First part of a two-course graduate product design experience in mechanical engineering. Covers problem definition and specifications, determining design requirements, user feedback, alternative design concepts, engineering analysis, concept prototypes and CAD drawings. Students make several oral design reviews, a final design presentation and prepare a written report. Entails a team product design, fabrication and testing cycle of sponsored project.

Course instructor(s):



Gregory Whiting



Rebecca Komarek

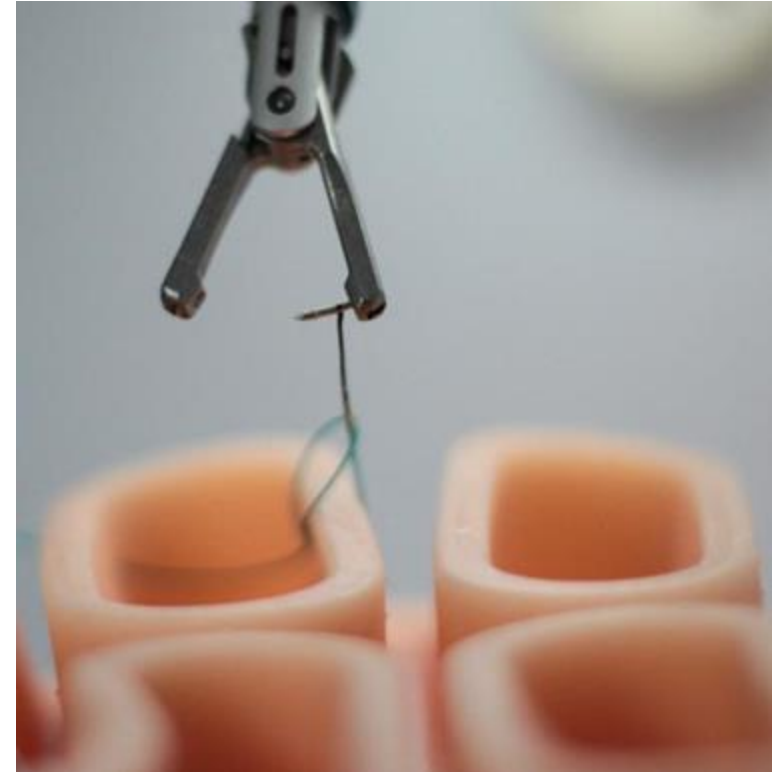

Teaching schedule: Offered every fall semester.



MCEN 5075: Graduate Product Design 2

Career Areas

Product Design

Specializations

Graduate Design Emphasis

Prerequisites

MCEN 5065: GPD 1

Pre or Corequisites

None

Second part of two-course graduate product design experience in mechanical engineering. Includes refinement of prototype, design optimization, fabrication, testing, and evaluation. Students orally present the final design and prepare a written report and operation manual for the product. Entails a team product design, fabrication, and testing cycle of a sponsored project, leading to a fully-functional product.

Course instructor(s):



Gregory Whiting



Rebecca Komarek

Teaching schedule: Offered every fall semester.



Tunable Oscillating and Rotational Kinematic Damper for Siemens Gamesa



MCEN 4115/5115: Mechatronics and Robotics 1

Career Areas

Robotics
Controls
Automated Systems
Integrated Systems

Specializations

None

Prerequisites

*ECEN 3010: Circuits**
*CSCI 1300: Programming**

Pre or Corequisites

None

**Or equivalent.*

Focuses on design and construction of microprocessor-controlled electro-mechanical systems. Lectures review critical circuit topics, discuss sensor and actuator component selection, microprocessor selection and programming, robotic systems, systems integration, and design strategies for complex, multi-system devices. Lab work reinforces lectures and allows hands-on experience with mechatronic design. Students must design and build an autonomous robotic device.

Course instructor(s):



Derek Reamon



Teaching schedule: Generally offered fall semester. Availability may vary based on instructor schedule.

MCEN 4117/5117: Anatomy and Physiology for Engineers I

Career Areas

*Biomedical Engineering
Medical Devices
Prosthetics*

Specializations

*BS Biomedical Option
BS Biomedical Minor*

Prerequisites

None

Pre or Corequisites

None

Explores human physiological function from an engineering, specifically mechanical engineering, viewpoint. Provides an introduction to human anatomy and physiology with a focus on learning fundamental concepts and applying engineering (mass transfer, fluid dynamics, mechanics, modeling) analysis.

Course instructor(s):



Wei Tan



Jessica Fitzgerald

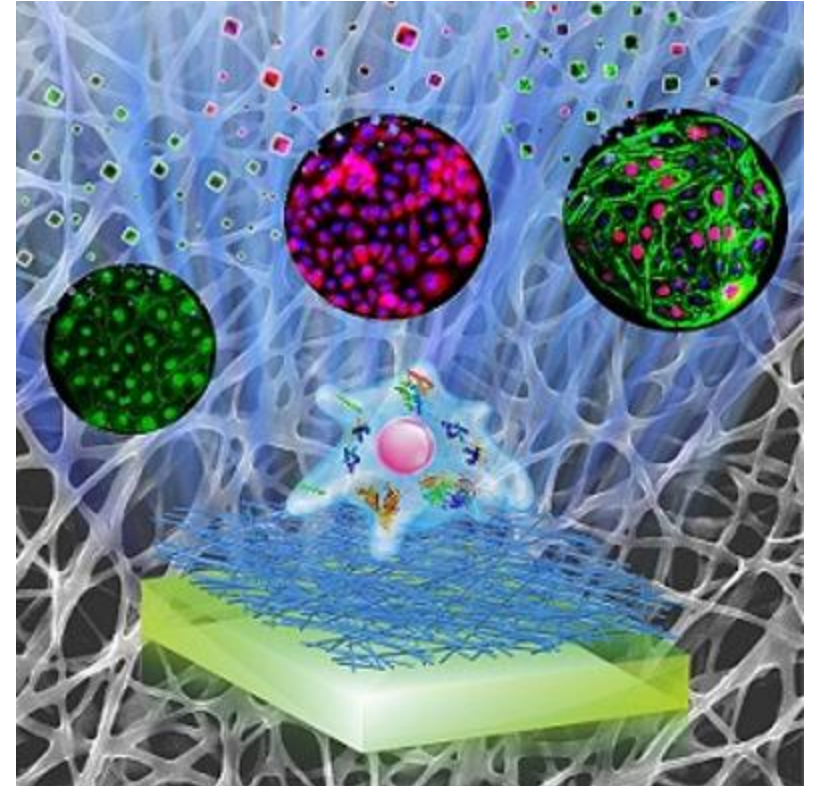

Teaching schedule: Offered both fall and spring semester. Taught in alternating semesters with BMEN.



MCEN 4125/5125: Optimal Design

Career Areas

Engineering Design
Modelling/Optimization

Specializations

None

Prerequisites

MCEN 3030: Comp
Methods*

Pre or Corequisites

None

*Or equivalent.

Learn how to formulate engineering optimization problems into mathematical forms that can be solved by standard software tools to find the "best" solution. Applications such as the minimum cost mechanical design, wind farm power maximization, minimum energy control, operations research, classification via support-vector machine, and even a Sudoku solver will be explored using the tools learned.

Course instructor(s):



Shalom Ruben

Teaching schedule: Generally offered every second year in the spring semester.

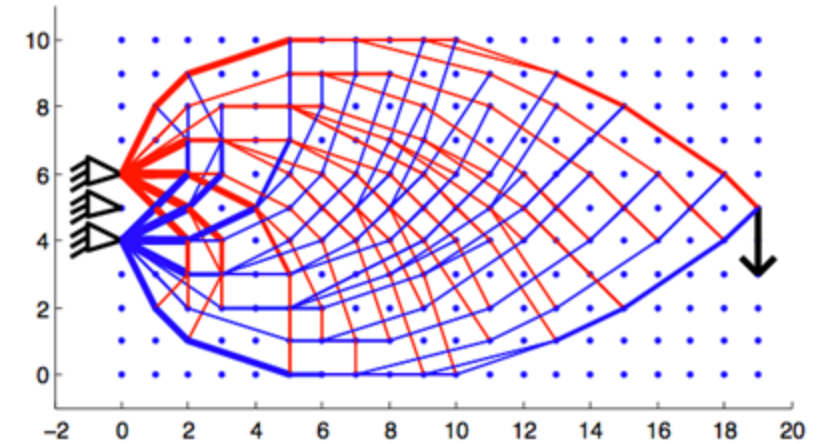

MCEN 4127/5127: Biomedical Ultrasound

Career Areas

*Imaging Technology
Biomedical Engineering*

Specializations

*BS Biomedical Option
BS Biomedical Minor*

Prerequisites

Senior standing (or above)

Pre or Corequisites

None

Covers the design of ultrasound systems for medical imaging and therapy, including the physics of wave propagation, transducers, acoustic lenses, pulse-echo imaging and cavitation dynamics, with an emphasis on current topics in biomedical ultrasound. Includes lectures on theory, practice and special topics; a laboratory on wave propagation; oral presentations on current literature; and a design project.

Course instructor(s):



Nick Bottenus



Mark Borden

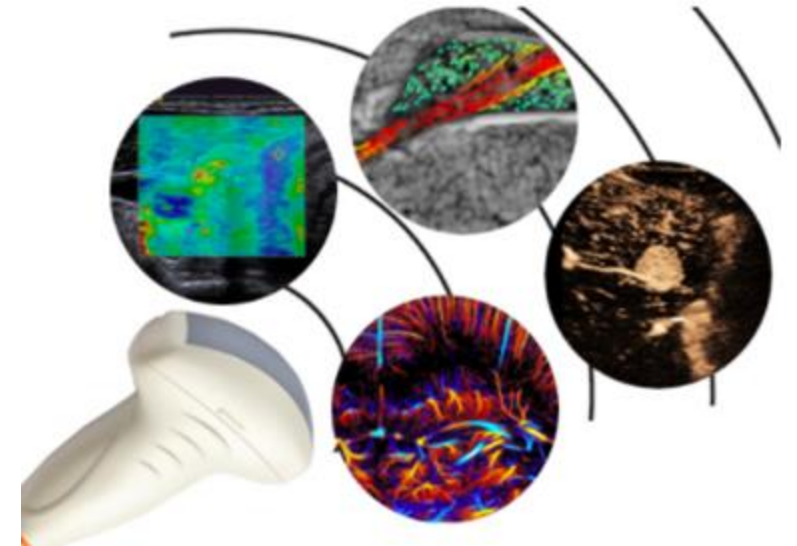

Teaching schedule: Generally offered Fall semester as instructor schedules allow.

MCEN 4131/5131: Air Pollution Control Engineering

Career Areas

Environmental Engineering
Environmental Consulting
Policy Analysis

Specializations

BS Environmental Option
BS Energy Minor

Prerequisites

MCEN 3012: Thermo*
MCEN 3021: Fluids*

Pre or Corequisites

None

*Or equivalent.

Introduces air quality regulations, physics and chemistry in the atmosphere, meteorology, and exposure. Examines methods for controlling major classes of air pollutants, including particulate matter and oxides of sulfur and nitrogen, as well as control technologies for sources such as coal power plants and motor vehicles. Requires interdisciplinary design projects. Approved for the Environmental Option.

Course instructor(s):



Shelly Miller



Nina Vance



Michael Hannigan

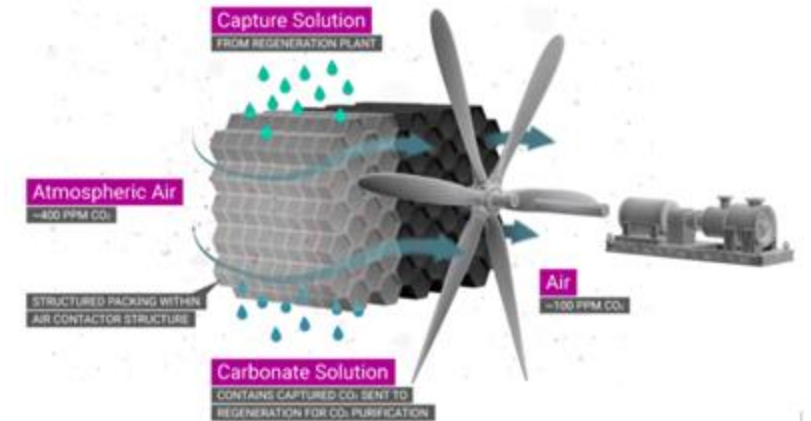

Teaching schedule: Offered every fall semester.



MCEN 4133/5133: Introduction to Tissue Biomechanics

Career Areas

*Medical Device Design
Prosthetics Engineering
Biomedical Engineering
Biomaterials Design
Clinical Care*

Specializations

*BS Biomedical Option
BS Biomedical Minor*

Prerequisites

MCEN 2024: Materials
MCEN 2063: Solids*
MCEN 3021: Fluids**

Pre or Corequisites

None

**Or equivalent*

Focuses on developing an understanding of the fundamental mechanical principles that govern the response of hard and soft biological tissue to mechanical loading. Specifically, covers mechanical behavior of biological materials/tissues, classical biomechanics problems in various tissues, the relationship between molecular, cellular and physiological processes and tissue biomechanics and critical analysis of related journal articles.

Course instructor(s):



Virginia Ferguson



Corey Neu



Teaching schedule: Offered every spring semester.



MCEN 4135/5135: Wind Energy

Career Areas

Renewable Energy

Specializations

BS Environmental Option

BS Energy Minor

Prerequisites

*ECEN 3010: Circuits**

*MCEN 3021: Fluids**

Pre or Corequisites

None

**Or equivalent.*

Learn the evolution of a wind energy project from development to operations. Study practical techniques for getting a project constructed and generating revenue. Create an awareness around the current policies and events in the industry. Topics will include: technical analysis during development; general approach to engineering wind turbine components; and economic evaluation for wind turbine selection. Approved for and sponsored by the Energy Minor.

Course instructor(s):



Roark Lanning



Teaching schedule: Offered every spring semester through the Energy Minor Program.



MCEN 4141/5141: Indoor Air Pollution

Career Areas

*Environmental Engineering
Environmental Consulting
Policy Analysis*

Specializations

*BS Environmental Option
BS Energy Minor*

Prerequisites

MCEN 3021: Fluids
MCEN 3022: Heat Transfer**

Pre or Corequisites

None

**Or equivalent.*

Describes the impact of indoor air pollutants on human health, including an introduction to key pollutants and their sources. Students will estimate emission factors, calculate generation/ventilation rates, quantify the impact of deposition and chemical reactions and explore relevant control technology. Current issues will also be addressed, including climate change, green building design, economic concerns, and relevance to the developing world.

Course instructor(s):



Shelly Miller

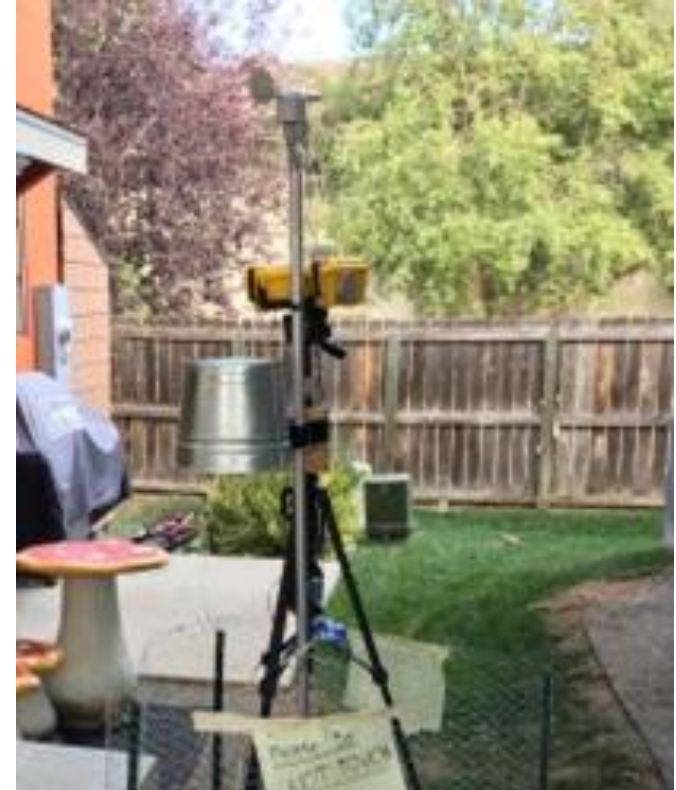

Teaching schedule: Availability varies. Offered as instructor schedules allow.

MCEN 5147: Mechanobiology

Career Areas

Healthcare
Biomedical Engineering
Exercise Sports Science
Physiology

Specializations

BS Biomedical Option
BS Biomedical Minor

Prerequisites

None

Pre or Corequisites

None

Current molecular mechanisms by which cells convert mechanical stimuli into chemical activity and the literature supporting them will be discussed. Students will acquire an understanding and expertise from the analysis of primary literature and completion of a synthesis project. This course will serve as the focal point of discourse for graduate students with research requiring an in-depth understanding of the interface of mechanics and molecular and cellular biology.

Course instructor(s):



Corey Neu

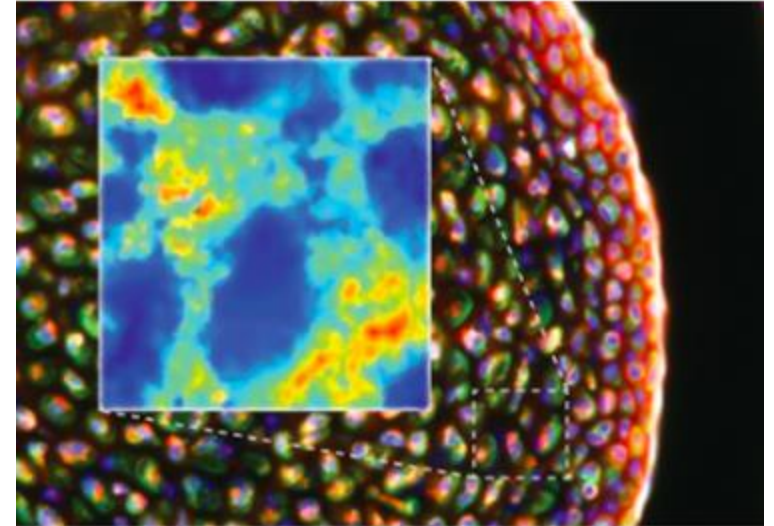

Teaching schedule: Availability varies. Offered as instructor schedules allow.

MCEN 4151/5151: Flow Visualization

Career Areas

Artistic Design
Fluid Mechanics

Specializations

None

Prerequisites

MCEN 3021: Fluids*

Pre or Corequisites

None

*Or equivalent.

Explores techniques for visualizing the physics of fluid flows including seeding with dyes, particles and bubbles, and shadowgraphy and schlieren. Reviews optics and fluid physics, especially atmospheric clouds. Assignments are student-driven, to individuals and mixed teams of graduates, undergraduates, engineering majors and photography/video majors.

Course instructor(s):



Jean Hertzberg

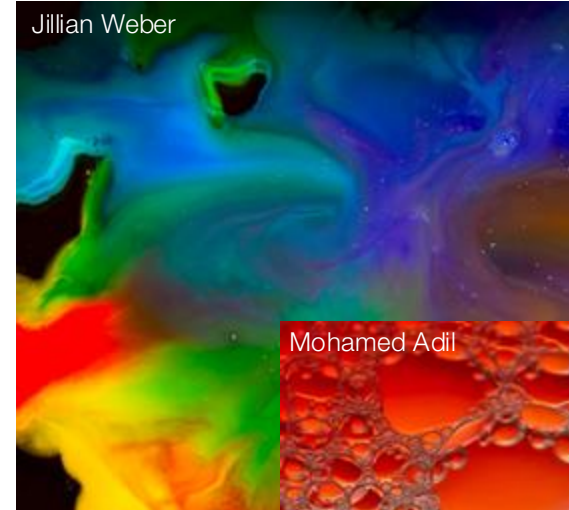

Teaching schedule: Generally offered once a year. Availability may vary based on instructor schedule.



MCEN 4152/5152: Introduction to Combustion

Career Areas

Energy Efficiency
Renewable Energy
Oil and Gas
Air Quality

Specializations

BS Environmental Option
BS Energy Minor

Prerequisites

*MCEN 3012: Thermo**
*MCEN 3021: Fluids***
*MCEN 3022: Heat Transfer***

Pre or Corequisites

None

**Or equivalent.*

***Recommended.*

Focuses on the mechanisms by which fuel and oxidizers are converted into combustion products. Application to practical combustion devices such as Otto, Diesel, gas turbine, and power plant combustion systems. Consideration of combustion-generated air pollution, fire safety, and combustion efficiency.

Course instructor(s):



Nicole Labbe



Teaching schedule: Generally offered fall semester. Availability may vary based on instructor schedule.



MCEN 5161: Aerosols

Career Areas

*Air Pollution Control
Atmospheric Science
Production Engineering*

Specializations

Environmental Option

Prerequisites

None

Pre or Corequisites

None

Introduces atmospheric aerosols and properties of their distributions, followed by fundamental descriptions of single particle dynamics, thermodynamics, nucleation, coagulation, mass transfer and populations dynamics. During the second half of the course, the focus will shift to sources and sinks of atmospheric aerosols, their impacts on atmospheric chemistry and radiation, and the impacts of these processes on air quality and climate.

Course instructor(s):



Marina Vance



Daven Henze



Teaching schedule: Availability varies. Offered as instructor schedules allow.



MCEN 4173/5173: Finite Element Analysis

Career Areas

Structural Engineering
Heat Transfer
Renewable Energy
Biomechanics
Advanced Materials

Specializations

None

Prerequisites

MCEN 2023: Statics*
MCEN 2063: Solids*

Pre or Corequisites

None

*Or equivalent.

The class is an introductory course of finite element analysis (FEA). It introduces the theory behind and applications of the finite element method as a general and powerful tool to model a variety of phenomena in mechanical engineering. It will cover the fundamental theory of FEA including FEA formulas for truss, beam, 2D and 3D elasticity problems, general theory and considerations of FEA. The lab session will give chances to apply the FEA tool to problems including structural mechanics, elasticity, and heat conduction. Approved for the Biomedical Option.

Course instructor(s):

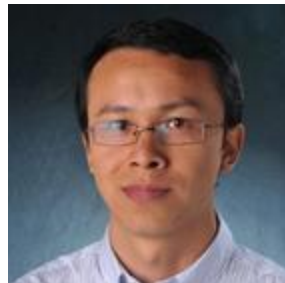

Jianliang Xiao



Jeff Knutsen

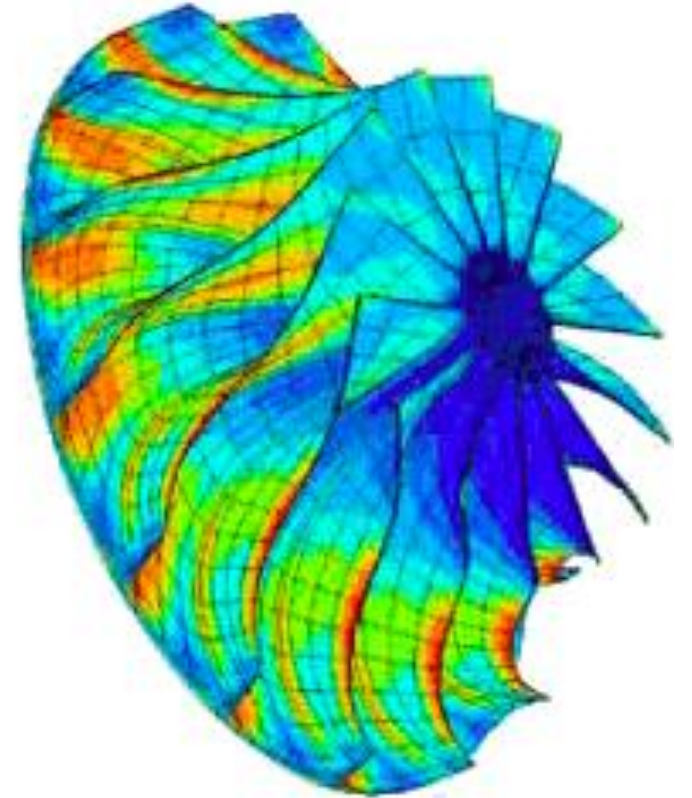

Teaching schedule: Offered every spring semester.



MCEN 4174/5174: Failure of Engineering Materials

Career Areas

Materials Engineering
Failure Analysis
Materials Selection

Specializations

None

Prerequisites

MCEN 2024: Materials*
MCEN 2063: Solids*

Pre or Corequisites

None

**Or equivalent.*

Examines the fundamental concepts regarding the failure of engineering materials. Case studies are used to integrate a basic understanding of material failure mechanisms with analysis techniques and tools. Topics include the elastic properties (isotropic and anisotropic materials) and the origin of elastic behavior, viscoelasticity, plasticity (dislocation mechanisms, yielding criteria, strengthening mechanisms), creep, fracture and fatigue.

Course instructor(s):



Todd Murray



Teaching schedule: Generally offered once a year. Availability may vary based on instructor schedule.



MCEN 4183/5183: Mechanics of Composite Materials

Career Areas

Aircraft Engineering
Automotive Engineering
Marine Engineering
Wind Energy
Infrastructure
Biomedical Applications

Specializations

None

Prerequisites

MCEN 2063: Solids*

Pre or Corequisites

None

*Or equivalent.

Composite materials offer advantageous material properties such as high strength, high stiffness, low density and long fatigue life. However, because composites consist of two or more material phases, the mechanics of composite materials is much more complex. This course will start with a brief review on the fundamentals of solid mechanics and then introduce the concepts required to analyze composite materials. Topics to be discussed include: elastic behavior and strength of composites, failure analysis, uni-directional and multi-directional lamina, and effects of temperature and humidity.

Course instructor(s):



Rong Long

Teaching schedule: Availability varies. Offered as instructor schedules allow.

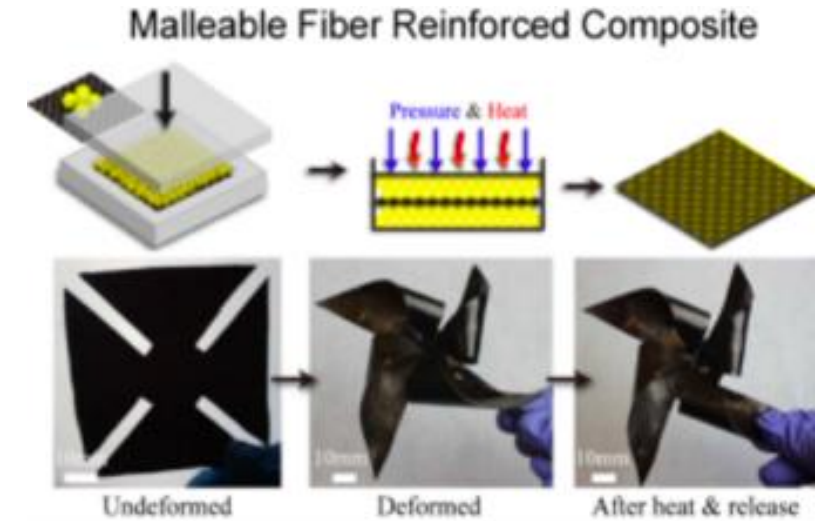

MCEN 4194/5194: Energy Conversion and Storage

Career Areas

Electric Vehicles

Energy Storage

Smart Grids

Portable Electronics

Fuel Cell Systems

Specializations

BS Energy Minor

Prerequisites

*MCEN 2024: Materials**

Pre or Corequisites

*MCEN 3032: Thermo 2**

**Or equivalent.*

Presents the fundamentals, principles and experimental techniques of electrochemistry, the background of ionic or electronic conduction of metal, semiconductor, inorganic and polymer materials, and applications in the areas of batteries, fuel cells, electrochemical double layer capacitors, electrochemical photonics, sensors and semiconductor electrochemistry.

Course instructor(s):



Se-Hee Lee

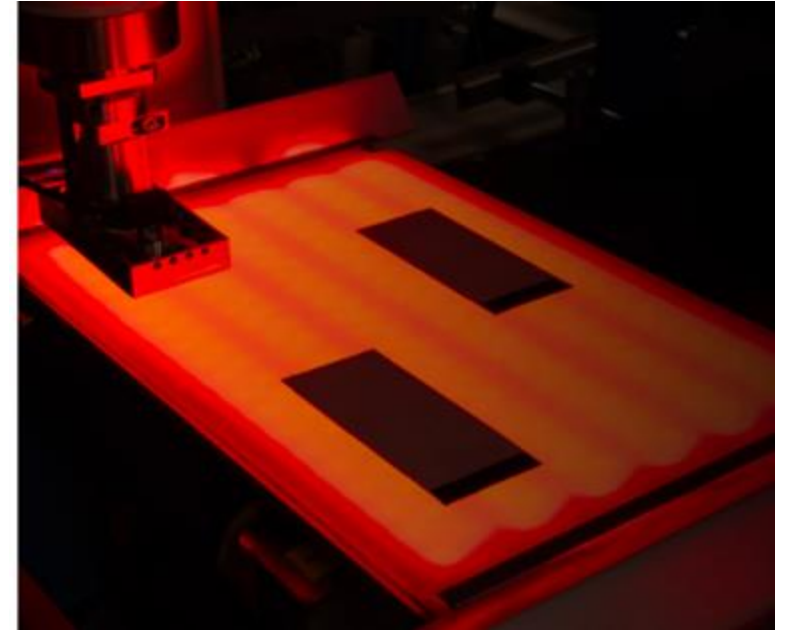

Teaching schedule: Availability varies. Offered as instructor schedules allow.

MCEN 5208: Introduction to Research

Career Areas

Research

Graduate Study

Specializations

None

Prerequisites

None

Pre or Corequisites

None

This course is meant to help students with major objectives of their first year of graduate school. These objectives include learning how to conduct research and communicate the results, developing an understanding of the ins and outs of getting a PhD and/or writing a Master's thesis, and building a community of peers and network of friends.

Course instructor(s):



Peter Hamlington



Maureen Lynch



Hope Michelsen



Teaching schedule: Offered every fall semester.



MCEN 5000 Sociotechnical Industry Skills

Career Areas
Industry

Specializations
None

Prerequisites
None

Pre or Corequisites
None

This course provides students with an introduction to professional skills as they relate to the practice of engineering. The primary focus areas are effective communication, ethics, leadership styles and philosophies, project management, and teamwork. Students will regularly engage with alumni and industry experts. This course is required for all professional master's students who joined the program in summer 2021 or later.

Course instructor(s):



Rebecca Komarek



Vera Sebulsky

Teaching schedule: Offered every spring semester.



MCEN 4228/5228: Thermofluids Lab

Career Areas

Energy Systems
Renewable Energy
Heating/Cooling

Specializations

BS Environmental Option
BS Energy Minor

Prerequisites

MCEN 3022: Heat Transfer*
MCEN 3032: Thermo 2*

Pre or Corequisites

None

*Or equivalent.

Strengthens understanding of how fundamental thermo-fluid concepts relate to real-world energy systems through hands-on laboratories with solar-thermal heaters, refrigeration cycles, cookstoves, combustors and more. Integrates concepts from thermodynamics, fluid mechanics, and heat transfer. Also emphasizes measurement practices and technical communication.

Course instructor(s):



Julie Steinbrenner



Greg Rieker



Jeff Knutsen



Teaching schedule: Availability varies. Offered as instructor schedules allow.



4228/5228 Surface Forces in Biology

Career Areas

Biomedical

Specializations

None

Prerequisites

None

Pre or Corequisites

None

Most materials display only one or two types of intermolecular interactions, while biological systems typically involve four or more interactions, simultaneously or sequentially in space and time. This course will help you build a quantitative molecular-level understanding of the diverse nanoscale forces acting between biological surfaces, including van der Waals, electrostatic, hydration, hydrophobic and thermal fluctuation interactions. Knowledge of these forces will be used to analyze self-assembly, biomembranes and engineering for drug delivery and imaging.

Course instructor(s):

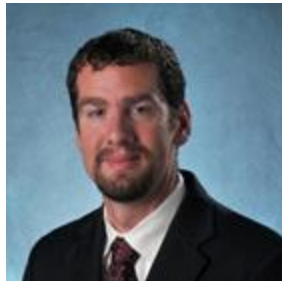

Mark Borden

Teaching schedule: Availability varies. Offered as instructor schedule allows.



4228/5228 Machine Learning in Mechanical Engineering

Career Areas

Data Science
Robotics Engineering
ML-enhanced CAD
Predictive Maintenance

Specializations

None

Prerequisites

*MCEN 3021: Fluid
Mechanics*
MCEN 3022: Heat Transfer
MCEN 4026: Manufacturing

Pre or Corequisites

None

This course explores the dynamic intersection of mechanical engineering and machine learning. We will delve into the state of the art integrating data science and machine learning algorithms with traditional mechanical engineering disciplines such as fluid and solid mechanics, heat transfer, control systems, materials, system design, and manufacturing.

Course instructor(s):

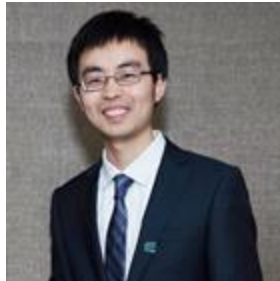

Longji Cui

Teaching schedule: Availability varies. Offered as instructor schedule allows.



4228/5228 Thermal Systems Analysis and Innovation

Career Areas

*Decarbonization
Sustainability
Renewable Energy
Solar Thermal Energy
Power Generation
Propulsion &
Transportation
Fuel Cell & Electrolysis
Systems*

Specializations

BS Energy Minor

Prerequisites

*MCEN 3012:
Thermodynamics
MCEN 3021: Fluid
Dynamics*

This course focuses on System Level Thinking, use of Requirements Flow Down and First-Principles Analysis as the backbone for Innovation and creative thinking in the domain of thermal system. It includes applying innovation methods so that students will have the experience and skills to engage in innovations in the rapidly changing world of renewable thermal energy and propulsion and power systems. Strengthens understanding of real-world energy systems. Also emphasizes technical communication for influence.

Course instructor(s):



Greg Hampson

Teaching schedule: Availability varies. Offered as instructor schedule allows.



4228/5228 Membrane Technologies

Career Areas

None

Specializations

None

Prerequisites

None

Pre or Corequisites

None

Membrane technologies are critical for addressing global challenges from sustainability to public health. Covers fundamentals and applications of membrane technologies. Topics include (1) basics of different types of separation membranes, (2) membrane materials and manufacturing processes, (3) membrane characterizations, (4) fundamentals of different membrane processes, (5) applications of membrane technologies for liquid separations such as desalination and ultrafiltration (UF), (6) gas separation using membranes, (7) membranes for energy applications such as fuel cells and batteries.

Course instructor(s):



Yifu Ding

Teaching schedule: Availability varies. Offered as instructor schedule allows.



4228/5228 Design of Beer

Career Areas

*Process Engineering
Manufacturing
Quality Control
Systems Engineering
Brewing/Distilling
Food Engineering
Chemical Engineering
Mechanical Engineering*

Specializations

None

Prerequisites

None

The Design of Beer is an excellent example of a product that encapsulates many scientific and engineering principles in all parts of the value chain – from raw materials production and selection through to manufacturing and brewhouse equipment design, quality control, marketing, packaging, and (of course) consumption. At the end of this course, students will understand the science underlying beer production, the engineering design of manufacturing and processing equipment, and quality control of the final product.

Course instructor(s):



[Dan Riffell](#)

Teaching schedule: Availability varies. Offered as instructor schedule allows.



4228/5228 Mechanics of Biological/Bioinspired Materials

Career Areas

*Mechanical Engineering
Bioinspiration
Bioengineering
Materials Science
Biology.*

Prerequisites

*MCEN 2063 Mechanics of
Solids or
MCEN 5023 Solid
Mechanics*

Covers the composition, structure and mechanics of biological materials at the molecular scale (proteins, polysaccharides) and at larger scales (bone, skin, spider silk, seashells, cuticles, etc.). Reviews experiments and models (micromechanics, large deformations, fracture mechanics) applied to biological. Discusses implications in biomechanics, biology and medicine, with a stronger emphasis on engineering materials inspired by biological materials (biomimetics, bioinspiration). Assessment is largely based on in-class activities and a final project.

Course instructor(s):



[Francois Barthelat](#)

Teaching schedule: Availability varies. Offered as instructor schedule allows.



MCEN 4155/5155: Automated Mechanical Design

Career Areas

*Mechanical Design
Design Automation
Additive Manufacturing
Robotics
Optimization
Mechanical Simulation*

Specializations

None

Prerequisites

MCEN 3030: Comp
Methods* (or)
MCEN 4043: System
Dynamics*

Pre or Corequisites

None

**Or equivalent.*

Multimaterial mechanical design is formulated as a constrained non-convex multi-objective optimization problem, and various algorithms to solve these optimization problems are discussed. Topics include: review of the expert-driven design process; computational analysis tools based on mechanical simulation (finite element methods, mesh-free methods); topological optimization; compositional design; multi-objective optimization; evolutionary design; design for manufacturing with additive manufacturing (FDM, SLA, Inkjet).

Course instructor(s):



Rob MacCurdy

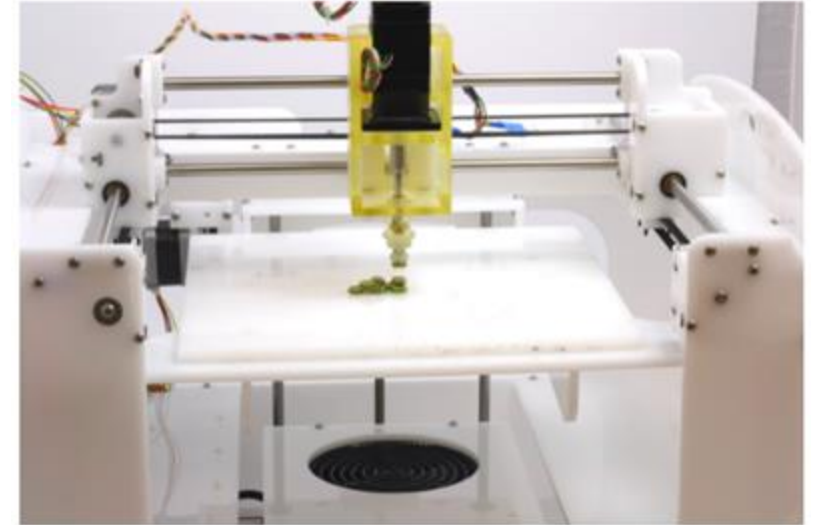

Teaching schedule: Generally offered spring semester. Availability may vary based on instructor schedule.



MCEN 4171/5171: Biofluids on the Micro Scale

Career Areas

Biomedical Devices

Lab on a Chip

Biomedical Engineering

Specializations

BS Biomedical Option

BS Biomedical Minor

Prerequisites

None

Pre or Corequisites

None

Fluid (water or air) is everywhere, surrounding or inside any living creature. The needs for engineers with integrated multidisciplinary knowledge are growing along with the rapid advances in biomedical science and engineering. This course is designed to introduce fundamental physical concepts and basic mechanisms of biological fluids. This course elaborates the application of fluid mechanics principles to major biological systems, including human organ systems, organ on a chip, and some animal locomotion.

Course instructor(s):



Xiaoyun Ding

Teaching schedule: Availability varies. Offered as instructor schedules allow.

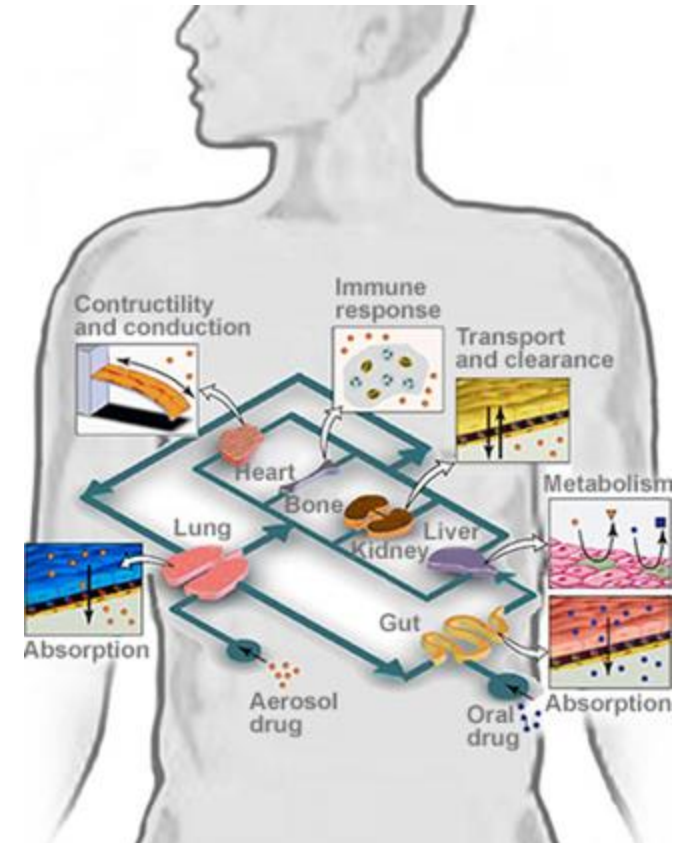

MCEN 4228/5228: Nano Science and Engineering

Career Areas

*Materials Science
Energy
Electronics*

Specializations

None

Prerequisites

None

Pre or Corequisites

None

This course is based on a book, "Introduction to NanoScience". It contains chapters on basic science (chemistry, physics, mechanical properties, spectroscopy and electrochemistry). Subsequent chapters address coalescence of the science and engineering (thin films, nanocrystals, nanocarbon, thermal conductivity of nanocomposites, lithium-ion batteries, molecular spectroscopy). The course focuses on applications. The unique feature is learning to build models that explain engineering data. This cross-disciplinary course is relevant to the fields of science, applied-science and engineering.

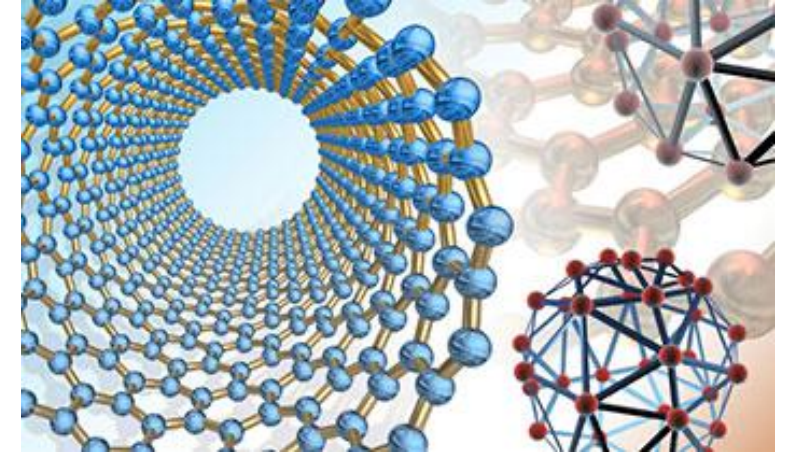

Course instructor(s):



Rishi Raj

Teaching schedule: Generally offered fall semester. Availability may vary based on instructor schedule.



MCEN 4228/5228: 3D Printing with Polymers

Career Areas

3D printing
Manufacturing
Polymer Materials

Recommended Pre or Co Prerequisites

MCEN 4298 Intro to Polymers
MCEN 2024 Materials Science
MCEN 3022 Heat Transfer
MCEN 2063 Mechanics of Solids
MCEN 5044 Mechanical Behavior of Materials

Students will learn about polymer additive manufacturing techniques including extrusion, material/binder jetting, sintering, and photopolymerization. Advantages and limitations will be discussed through the lenses of polymer science, heat and mass transfer, and mechanical behavior of materials. Design principles and characterization techniques for 3D printed materials will also be covered. The course will culminate with a hands-on project in the Idea Forge to create a useful object, toy, or small piece of research equipment.

Course instructor(s):



[Max Saccone](#)

Teaching schedule: Availability varies based on instructor schedule.

MCEN 5228: Introduction to Wildfires

Career Areas

Thermofluids
Air Quality
Atmospheric Sciences

Prerequisites

MCEN 3012
Thermodynamics
or equivalent

In the wake of climate change, there is a growing risk and frequency of extremely destructive, uncontrolled wildland fires and fires at the wildland-urban interface (WUI) and a need to mitigate and control such fires. This course will delve into the science of wildfires, covering the current understanding of wildland and WUI fires, including fuel effects, combustion regimes, ignition, propagation, emissions, and environmental impacts. This field is rapidly evolving, and, although there will be a textbook, much of the class will be devoted to exploring the current research on the topic.

Course instructor(s):



[Hope Michelsen](#)

Teaching schedule: Availability varies based on instructor schedule.



MCEN 5228: Introduction to Batteries

Career Areas

Electrochemistry

Prerequisites

None

This course provides a foundational understanding of batteries including electrochemistry, electrode, and electrolyte materials, working principles, and applications. Students will explore the science behind energy storage, including electrochemical reactions, battery types (such as lithium-ion, lithium-metal, solid-state, beyond lithium-ion batteries), and their performance characteristics. The course covers key topics such as materials selections, battery characterization and operation, safety, and emerging technologies in energy storage. Hands-on demonstrations and case studies will be used to help understanding the learning experience, equipping students with the knowledge to understand and analyze battery technologies.

Course instructor(s):



[Chunmei Ban](#)

Teaching schedule: Availability varies based on instructor schedule.



MCEN 4231/5231: Computational Fluid Dynamics

Career Areas

*Biomedical Engineering
Energy Engineering
Transportation
Defense Industry
Manufacturing
Environmental Applications*

Specializations

None

Prerequisites

MCEN 3021: Fluids
MCEN 3030: Comp
Methods**

Pre or Corequisites

None

**Or equivalent.*

This course will provide a broad introduction to the basic principles and applications of Computational Fluid Dynamics (CFD). The core focus will be on computational solutions of flow and transport problems using the finite element method. Students will learn about the mathematical fundamentals of the finite element method, as well as techniques for geometry handling, mesh generation, assembly and solution of matrix systems derived from the governing equations, and post-processing of the resultant numerical solution.

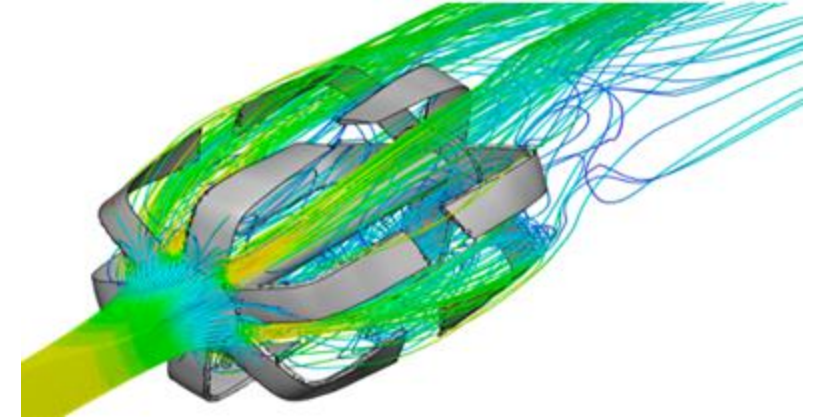

Course instructor(s):



[Debanjan Mukherjee](#)

Teaching schedule: Generally offered spring semester. Availability may vary based on instructor schedule.



MCEN 4215/5215: Design for Inclusion

Career Areas

Product Design
Social Justice
Critical Analysis

Specializations

None

Prerequisites

None

Pre or Corequisites

None

Are robots racist? Are algorithms oppressive? How do we end up with technologies that are optimized for some users, but scarcely meet the needs of others? In this era of upheaval and inequity, how should we be thinking about who benefits or who is harmed by a product? How can we as engineers even begin to answer these questions? The Design For Inclusion (DFI) course will examine the ways modern inventions like apps, products, public infrastructures and educational systems are biased, and what we as socially conscious engineers and designers can and should do about it.



Course instructor(s):



Janet Tsai



Teaching schedule: Generally offered spring semester. Availability may vary based on instructor schedule.



MCEN 4228/5228: Industrial Automation

Career Areas

Controls

Robotics

Industrial Systems

Specializations

None

Prerequisites

MCEN 4043: System Dynamics*

Pre or Corequisites

None

*Or equivalent.

Industrial applications of control are presented in this course including experimentation on a magnetic bearing system, where an unstable rotor is actively positioned at the shaft ends by electro-magnets using hall-effect sensors as feedback. All algorithms will be implemented on industrially used real-time control hardware. Methods for system identification of dynamical systems from input/output data, digital signal processing, and digital control of mechatronic systems will be learned.

Course instructor(s):



Shalom Ruben

Teaching schedule: Generally offered every second year in the spring semester.

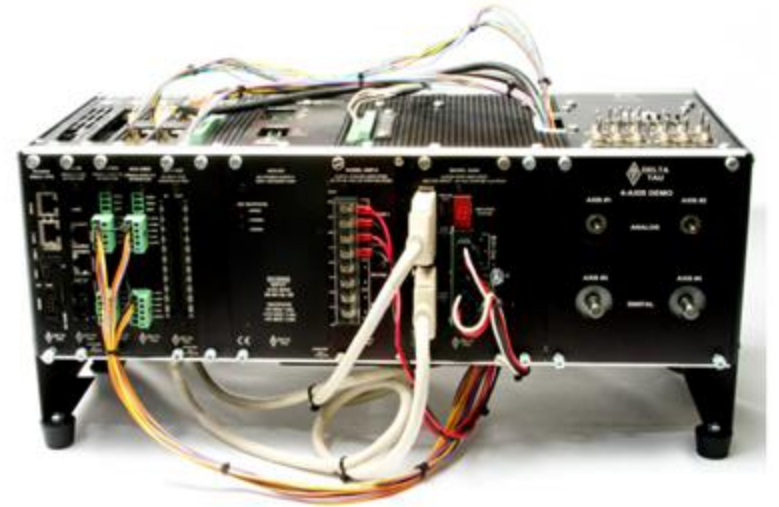

MCEN 4012/5012: Renewable Fuels, Fuel Cells, and Internal Combustion Engines

Career Areas

Combustion Engines
Combustion Devices

Specializations

None

Prerequisites

MCEN 3032: Thermo 2*

MCEN 4152/5152:

Combustion

Pre or Corequisites

None

*Or equivalent.

With the accelerated availability of Carbon Free and Renewable Fuels, we will explore high efficiency, low emissions Fuel Cell and Internal Combustion Engine energy conversion technologies, preparing students to enter the rapidly changing fields of power and propulsion on the path to Net-Zero Greenhouse Gas Emissions. Through Thermodynamics Modeling, Systems Engineering, and Requirements Flow Down, students will apply the fundamentals of thermodynamics, fluids and heat transfer, combustion and electro-chemistry to fuel cells and IC Engines.

Course instructor(s):



Greg Hampson

Teaching schedule: Availability varies. Offered as instructor schedules allow.

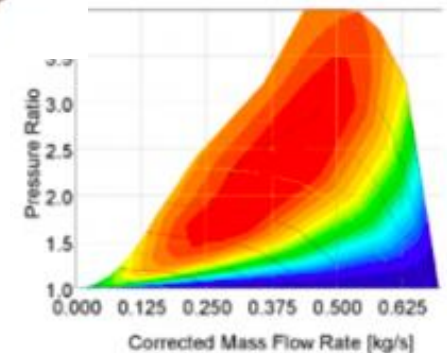

MCEN 4228/5228: Inverse Methods

Career Areas

Environmental Engineering
Imaging
Geophysical Engineering
Statistics
Optimization

Specializations

None

Prerequisites

Linear Algebra

Pre or Corequisites

None

What is an inverse problem? "Using a physical theory for predicting the results of observations corresponds to solving the 'forward modelling problem'. The reciprocal situation, using the result of measurements to infer the values of the parameters representing a system, corresponds to the 'inverse modelling problem'." This course will address fundamental aspects of inverse problems that arise in an array of engineering and geophysical applications, such as tomography, remote sensing, flux inversions, seismology, image reconstruction, and signal processing.

Course instructor(s):



Daven Henze

Teaching schedule: Availability varies. Offered as instructor schedules allow.

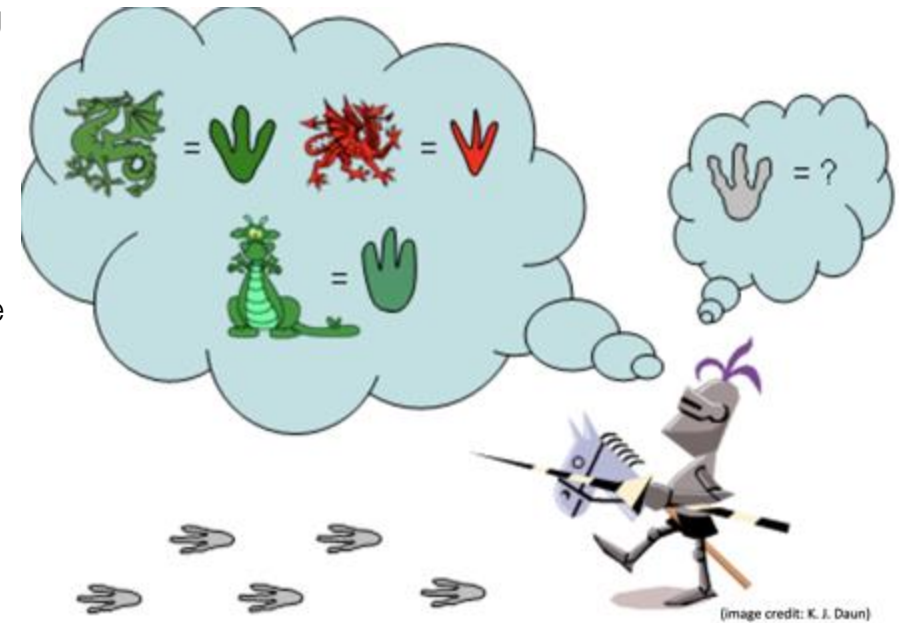

MCEN 4228/5228: Biohybrid Robotics

Career Areas

Animal Kinematics
Bioengineering
Biology
Electrical Engineering
Fluid Dynamics
Mechanical Engineering
Robotics

Specializations

Biomedical
Robotics

Prerequisites

None

Biohybrid robotics is a growing interdisciplinary field in which live components are integrated into engineered systems to address both biological questions and bottlenecks in traditional robotics, such as power constraints and dexterity. Such methods include using bacteria and other microorganisms, tissue engineering of cardiac and skeletal muscles, and cyborg techniques to direct the locomotion of live animals. Students will engage in lectures and laboratory components that incorporate microelectronics, additive manufacturing, and image processing to build and study biohybrid systems with live plants, insects, and jellyfish.

Course instructor(s):



[Nicole Xu](#)

Teaching schedule: Availability varies. Offered as instructor schedules allow.



MCEN 4036: Lean Six Sigma Manufacturing

Career Areas

Manufacturing
Quality Control
Management

Specializations

None

Prerequisites

None

Pre or Corequisites

None

This course focuses on Lean principles and Six-sigma methodologies for defining, measuring, analyzing, improving and controlling (DMAIC) processes in order to create more efficient processes. Skillsets that will be learned include; value stream maps, SIPOCS, statistical process control, GR&R studies, statistics, graphical representation, and Minitab. This course has shown to be successful in training your brain to think differently about processes through identifying wastes and improving processes to be more efficient.

Course instructor(s):



Jenifer Blacklock

Teaching schedule: Availability varies. Offered as instructor schedules allow.



MCEN 4113/5113: Mechanics of Cancer

Career Areas

Biomedical Engineering

Clinical Care

Tissue Engineering

Biomechanics for Cancer

Specializations

BS Biomedical Option

BS Biomedical Minor

Prerequisites

MCEN 2063: Solids*

MCEN 3021: Fluids*

Pre or Corequisites

None

*Or equivalent.

This course will cover the role of mechanics (emphasis on solid and fluid mechanics) in cancer and cancer-related processes. Course content includes experimental systems used to model and test these processes. No prior knowledge of biology is required to take this course. A limited overview of relevant biological processes will be covered as necessary.

Course instructor(s):



Maureen Lynch

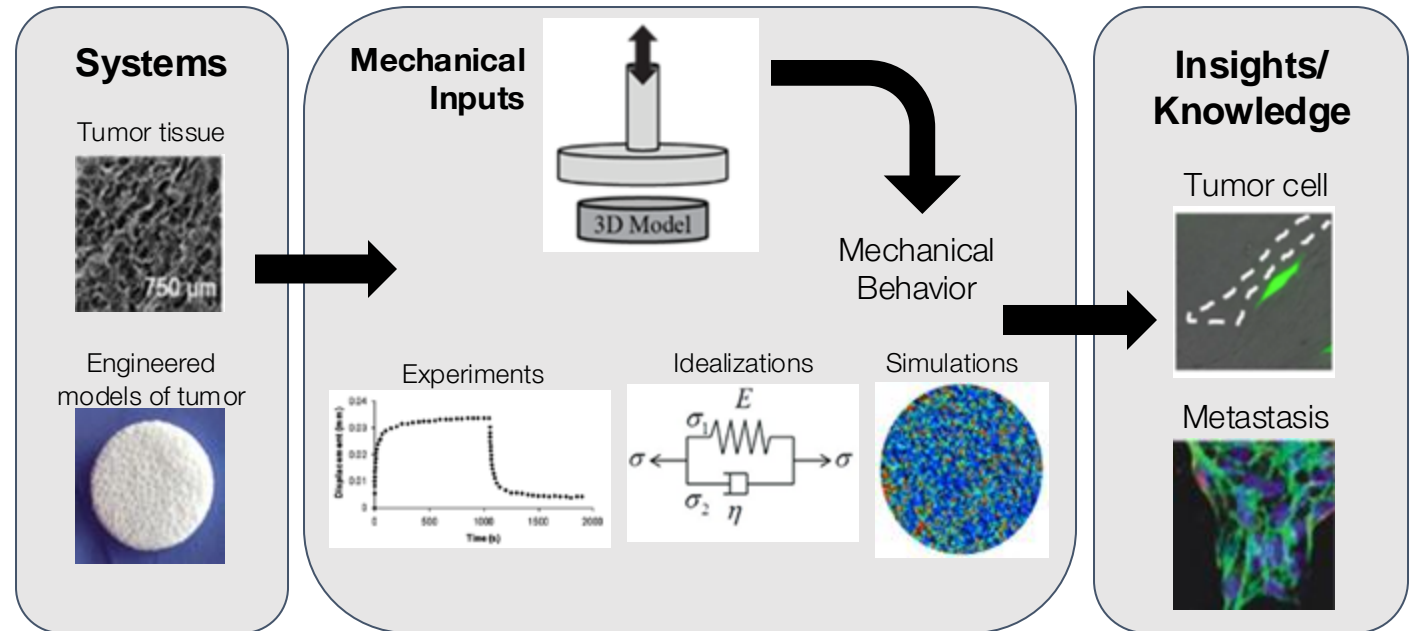

Teaching schedule: Generally offered spring semester. Availability may vary based on instructor schedule.



MCEN 4228/5228: Thin Film Materials

Career Areas

Text

Specializations

None

Prerequisites

MCEN 2063: Solids*

Pre or Corequisites

None

*Or equivalent.

This class is to give an introductory course to thin film materials. The topics include: (1) Deposition and processing of thin film materials, (2) Theory of elastic beams, plates and 3D solids, (3) Film stress and substrate curvature, (4) Thin film on stiff substrates and applications to coatings, (5) Thin film on compliant substrates, and applications on flexible/stretchable electronics, (6) Modeling of adhesives, (7) Other applications.

Course instructor(s):

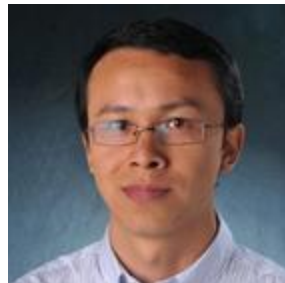

Jianliang Xiao

Teaching schedule: Availability varies. Offered as instructor schedules allow.

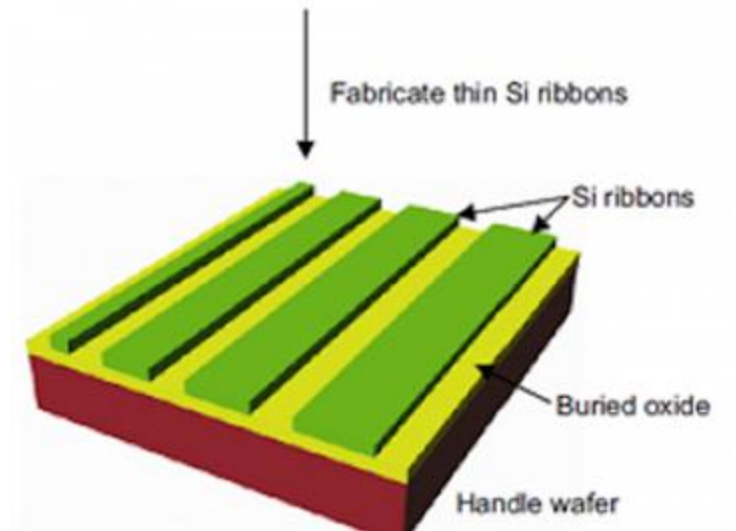

MCEN 4228/5228: Vibrations

Career Areas

*Structural Engineering
Modeling/Simulation
Product Testing
Engineering Design*

Specializations

None

Prerequisites

None

Pre or Corequisites

None

The course will provide an introduction to the dynamics of discrete and continuous mechanical systems, and will focus on the description of their response to a variety of excitation sources, including impulsive, harmonic and periodic. The dynamic response will be described in terms of modal properties, which include natural frequencies, mode shapes and damping ratios. The concept of resonance will be introduced in the context of forced response and will be illustrated through practical examples and numerical simulations. Application case studies will be presented to describe the vibrations of structural components, and basic concepts for vibration.

Course instructor(s):



Massimo Ruzzene

Teaching schedule: Availability varies. Offered as instructor schedules allow.



MCEN 4228/5228: Mechanics of Snow

Career Areas

*Avalanche Mechanics
Winter Sports
Land Management*

Specializations

None

Prerequisites

*MCEN 2063: Solids**

Pre or Corequisites

None

**Or equivalent.*

This course will introduce key concepts in the mechanics of snow over a wide range of time and length scales. Several concepts in solid mechanics will be covered in this process, including elasticity, viscoelasticity, micromechanics, failure criteria, damage mechanics, fracture mechanics, instabilities and cellular solids. Using these concepts we will describe the crystallographic structure of ice and snow, and how to connect this microstructure and its evolution over time to its mechanical properties.

Course instructor(s):



Francois Barthelat



Franck Vernerey



Teaching schedule: Availability varies. Offered as instructor schedules allow.



MCEN 4228/5228: Climate Engineering

Career Areas

Air Quality Engineering

Specializations

None

Prerequisites

None

Pre or Corequisites

None

Introduces the technical aspects of climate intervention, with particular focus on carbon dioxide removal (CDR) and solar radiation management (SRM) techniques. Discusses the destruction of the ozone layer and implementation of the Montreal Protocol as a framework for understanding the potential trajectory of climate intervention. Addresses the governance, ethics, and justice implications of CDR and SRM approaches.

Course instructor(s):



[Kelvin Bates](#)

Teaching schedule: Availability varies. Offered as instructor schedules allow.



MCEN 4228/5228: Advanced Biotransport

Career Areas

Biomedical

Specializations

None

Prerequisites

None

Pre or Corequisites

None

Builds on fundamentals of biological fluid mechanics, mass transfer and biochemical reaction kinetics to analyze physiological biotransport processes, including fluid transport in the circulation and tissues, transport in porous media, transvascular transport, oxygen transport, cell adhesion, immunogenicity, toxicity, transport of drugs in tumors, and pharmacokinetic modeling. Special emphasis will be placed on engineering solutions for delivery and removal of molecules in the human body.

Course instructor(s):



[Mark Borden](#)

Teaching schedule: Availability varies. Offered as instructor schedules allow.



MCEN 4195/5195: Bioinspired Robotics

Career Areas

Engineering Design

Robotics

Biomedical Engineer

Art/Architecture

Specializations

None

Prerequisites

None

Pre or Corequisites

None

In this course, you will learn how to build robots by leveraging principles of bioinspired design. Specifically, bioinspired design views the process of how we learn from nature as an innovation strategy translating principles of function, performance and aesthetics from biology to human technology. Lectures will address the biomimicry design process from original scientific breakthroughs to entrepreneurial start-ups using cases studies that include gecko-inspired adhesives, robots that run, fly and swim, artificial muscles, computer animation and more.

Course instructor(s):



[Kaushik Jayaram](#)

Teaching schedule: Generally offered spring semester. Availability may vary based on instructor schedule.

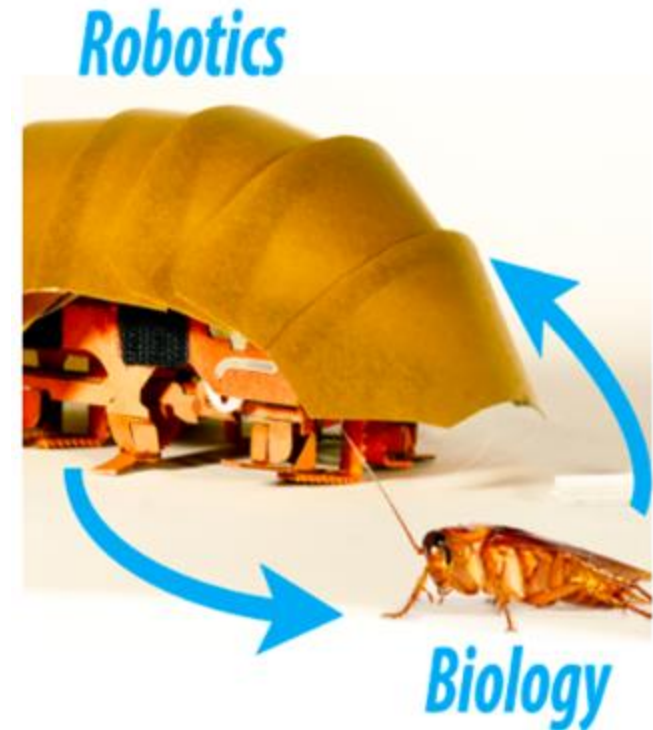

MCEN 4228/5228: Fluid Mechanics in the Human Body

Career Areas

Biomedical Engineering
Healthcare
Medical Devices
Medical Imaging
Precision Biomedicine

Specializations

BS Biomedical Option
BS Biomedical Minor

Prerequisites

MCEN 3021: Fluids**

Pre or Corequisites

None

**Recommended.

This course will provide a formal introduction to principles of biofluid mechanics at the macroscopic physiological scales. The average living human body is filled with fluids of over two dozen varieties – each performing key functions essential for life and well-being. Developing a core understanding of macroscale physiological flows is essential for key advances in healthcare and medical technology. We will explore the use of engineering principles of fluid flows and fluid-solid interactions to study physiological flow phenomena. This will include discussions of physiological processes in healthy and diseased states. The course will also explore latest advances in medical imaging and image-based flow analysis.

Course instructor(s):



Debanjan Mukherjee

Teaching schedule: Generally offered once a year. Availability may vary based on instructor schedule.

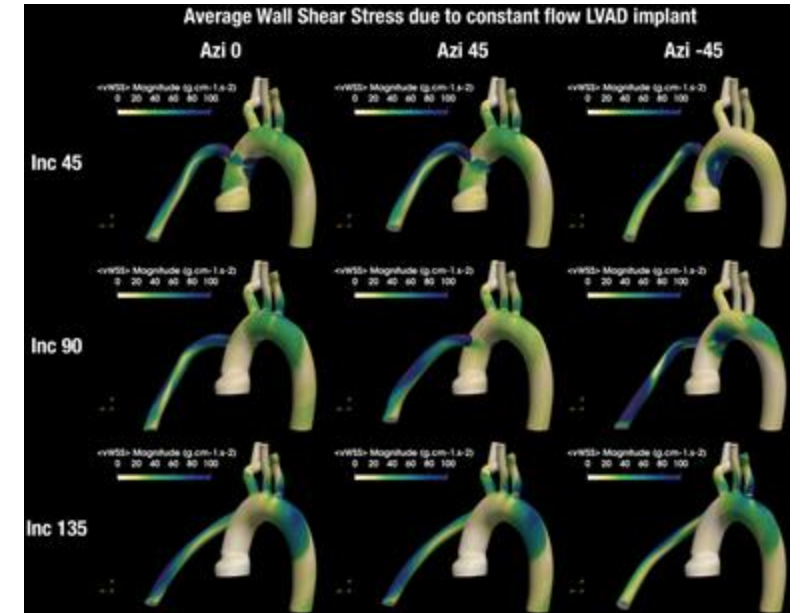

MCEN 4193/5193: Design of Coffee

Career Areas

Food Engineering
Sustainable Agriculture

Specializations

BS Biomedical Minor
BS Global Eng. Minor

Prerequisites

None

Pre or Corequisites

None

This class will serve as an introduction to how engineers use their training to approach and solve problems outside of their discipline, as illustrated by the roasting and brewing of coffee. In addition to focusing on the science and craftsmanship of making a cup of coffee from bean to cup, we will also study the global sourcing of coffee beans. The course will offer weekly hands-on experimental laboratories to demonstrate key engineering principles in subject areas such as heat transfer, mass transfer, thermodynamics, materials science, sustainability, water quality, biomedical engineering and device design evaluation. This class culminates in a design competition where students compete to make the best coffee using the least energy.

Course instructor(s):



Carmen Pacheco-
Borden



Teaching schedule: Generally offered fall semester. Availability may vary based on instructor schedule.

MCEN 4138/5138: Feedback Control

Career Areas

Controls
Robotics

Specializations

None

Prerequisites

MCEN 4043: System Dynamics*

Pre or Corequisites

None

*Or equivalent.

Introduction to fundamental principles and techniques for analysis and synthesis of feedback control systems in the time and frequency domains. Linearization, review of linear system response, frequency response, transfer functions and Bode diagrams. Closed loop system analysis including root locus, Nyquist criterion, gain and phase margins. Compensation design with lead, lag and PID controllers. Translation of closed loop performance requirements into open loop constraints. Model uncertainty and robustness. Introduction to state space representations and state feedback control.

Course instructor(s):



Shalom Ruben



Lucy Pao



Teaching schedule: Offered both fall and spring semester. Taught in alternating semesters with ECEN.



MCEN 4111/5111: Introduction to Microfluidics

Career Areas

Lab on a Chip
Biomedical Microdevices
Micro/Nanotechnology

Specializations

BS Biomedical Option
BS Biomedical Minor

Prerequisites

MCEN 3021: Fluids*

Pre or Corequisites

None

*Or equivalent.

Microfluidics deals with the behavior of fluids in small scale. It is a highly multidisciplinary field at the intersection of engineering, physics, chemistry, biology, medicine, nanotechnology, and biotechnology. This course is designed for a wide audience in engineering and science. It covers the fundamentals and fabrication of microfluidic devices, and their applications, particularly in lab on a chip. It includes lectures, team presentations, and possibly one laboratory on microfluidic devices. Mastery will enhance your understanding of microfluidic technologies and their broad applications.

Course instructor(s):

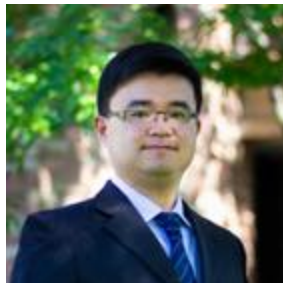

Xiaoyun Ding

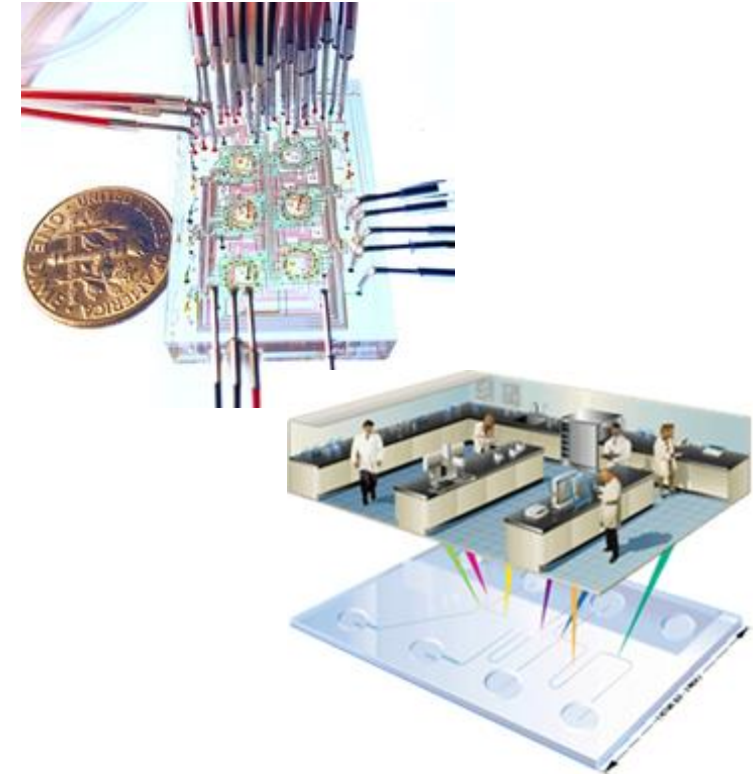

Teaching schedule: Generally offered once a year. Availability may vary based on instructor schedule.

MCEN 4157/5157: Modeling of Human Movement

Career Areas

*Biomechanics
Movement Rehabilitation
Robotics
Neuroscience*

Specializations

*BS Biomedical Option
BS Biomedical Minor*

Prerequisites

None

Pre or Corequisites

None

Human movement analysis is used in a wide range of applications, from physical rehabilitation to sport training, human-robot interaction and animation. The course will provide a systematic overview of human movement on multiple levels of analysis, with an emphasis on the phenomenology amenable to computational modeling. Topics will include muscle physiology, movement-related brain areas, musculoskeletal mechanics, forward and inverse dynamics, optimal control and Bayesian inference, learning and adaptation. The focus will be on reaching and locomotion as representative human movements.

Course instructor(s):



[Alaa Ahmed](#)



Teaching schedule: Generally offered once a year. Availability may vary based on instructor schedule.



MCEN 4110/5110: Regenerative Biology and Tissue Repair

Career Areas

Healthcare
Biomedical Engineering

Specializations

None

Prerequisites

None

Pre or Corequisites

None

This course will cover the biological aspects behind the regeneration/repair and the utilization of engineering strategies to restore functionality of tissues compromised by injury and disease. A range of tissues, including epidermal, neural, digestive, respiratory, digestive, musculoskeletal and cardiovascular, will be discussed based on student interest. Key topics critical for understanding the biological underpinnings of tissue regeneration (e.g. immune response, cell-matrix interactions) will be emphasized. Students will be required to read and present on the primary literature and over the course of the semester will develop a mini-proposal that will address an unsolved problem in regenerative medicine/engineering.

Course instructor(s):



Sarah Calve

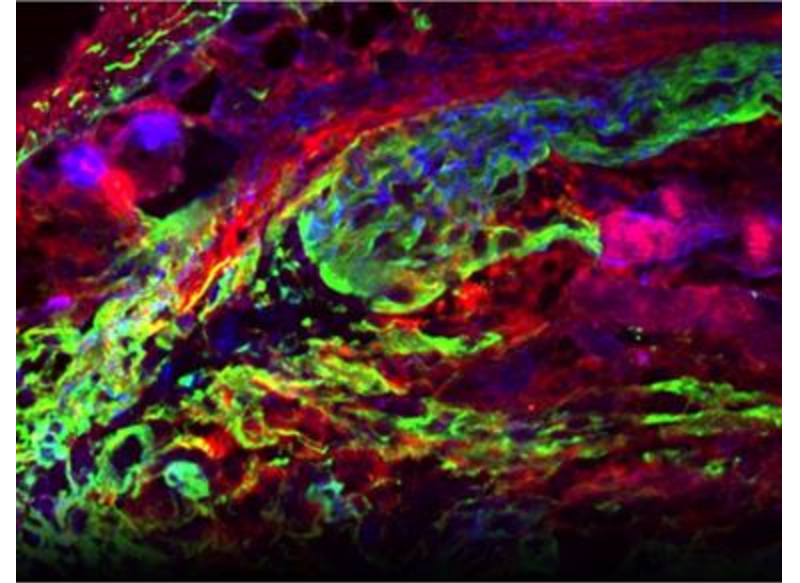

Teaching schedule: Generally offered once a year. Availability may vary based on instructor schedule.



MCEN 4228/5228: Introduction to Nanoscale Transport

Career Areas

*System Test/Diagnosis
Nanotech Manufacturing
Microelectronics
Nano-Optics
Quantum Technologies*

Specializations

None

Prerequisites

None

Pre or Corequisites

None

This course covers the basic concepts and methods to understand nanoscale transport phenomena that are ubiquitous in microelectronics, nano-enabled renewable energy technology, heat transfer, nano-optics, Micro/Nano-Electro-Mechanical- Systems (MEMS/NEMS), as well as emerging quantum technologies. Relevant laboratory and real-world applications and examples will be discussed. Topics include basics of solid-state physics and quantum mechanics, nano-electronic transport, nanoscale heat transfer, and more.

Course instructor(s):

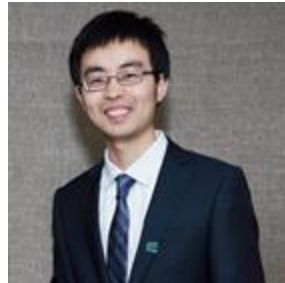

Longji Cui

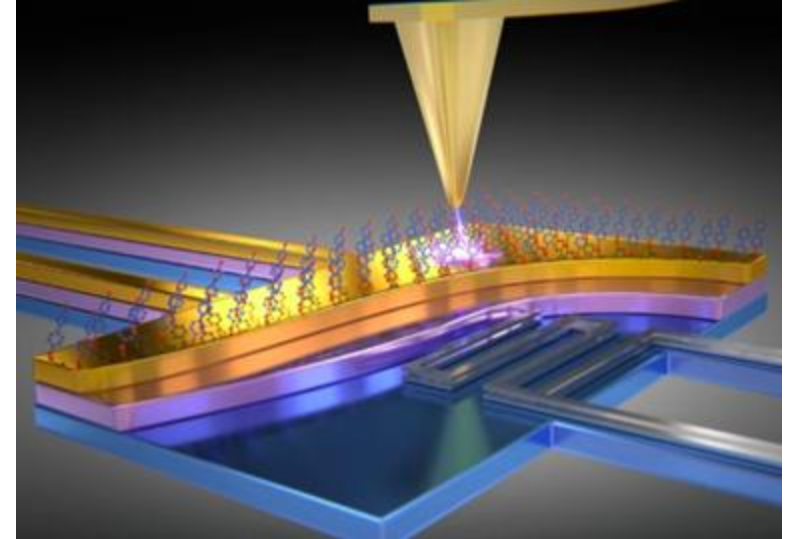

Teaching schedule: Availability varies. Offered as instructor schedules allow.



MCEN 4228/5228: Design Research Theory and Methods

Career Areas
Design

Specializations
None

Prerequisites
None

Pre or Corequisites
None

Provides an in-depth introduction to design science research, focusing on the scientific study of how people develop new products, systems, and services. Students will explore design practices, methodologies, and techniques that enhance design outcomes. The course emphasizes a comprehensive understanding of the artifacts, people, and institutions involved in design, while also covering the evaluation of design practices and the assessment of the broader societal impacts of engineered solutions. Students will develop skills to systematically and critically analyze and improve the processes of innovation and creation.

Course instructor(s):



Grace Burleson

Teaching schedule: Availability varies. Offered as instructor schedules allow.



MCEN 4228/5228: Mechatronics and Robotics 2

Career Areas

Robotics

Controls

Automated Systems

Integrated Systems

Specializations

None

Prerequisites

MCEN 4115/5115:

Mechatronics 1 (or)

Instructor Permission

Pre or Corequisites

None

Continuation of MCEN 4115/5115. Focuses on design and construction of advanced microprocessor-controlled electro-mechanical systems. Lectures explore computer vision, machine learning, feedback control, multi-processor coordination and other advanced topics in mechatronics and robotics. Lab work reinforces lectures and allows hands-on experience with mechatronic design. Team-based design project integrates content into class-chosen design challenge. Robots from Mechatronics 1 can be adapted or refined for use in the new design challenge. Mechatronics 1 and 2 do not have to be taken in the same year.

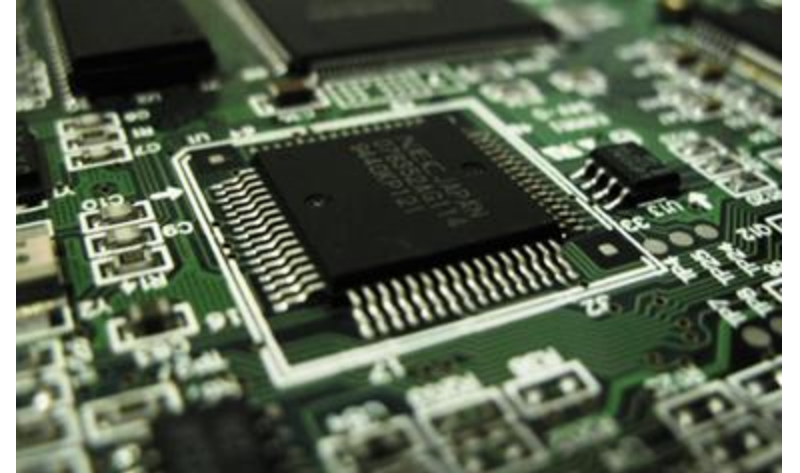

Course instructor(s):



[Derek Reamon](#)

Teaching schedule: Availability varies. Offered as instructor schedules allow.



MCEN 5228: Advanced Dynamics

Career Areas

Robotics
Controls
Modeling
Dynamic Systems

Specializations

None

Prerequisites

None

Pre or Corequisites

None

This course covers advanced theory for formulating and analyzing dynamical systems, including Newtonian, Lagrangian and Hamiltonian methods. Additional topics include equilibria, stability, Lyapunov functions, limit cycles, conservation laws and basic bifurcation theory.

Course instructor(s):



Sean Humbert

Teaching schedule: Availability varies. Offered as instructor schedules allow.

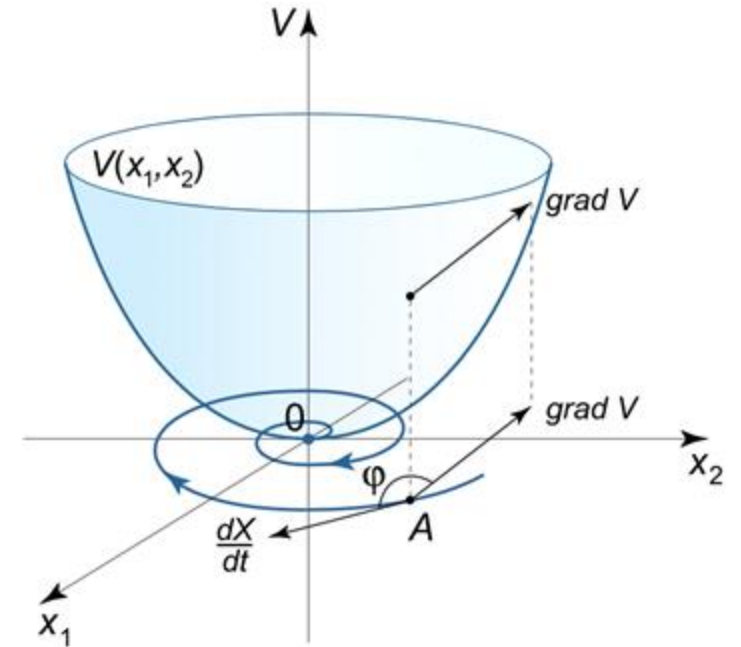

<https://math24.net/method-lyapunov-functions.html>



MCEN 5228: Flexible Electronics

Career Areas

*Smart Electronics
Materials Science
Engineering Design*

Specializations

None

Prerequisites

*MCEN 2063: Solids**

Pre or Corequisites

None

**Or equivalent.*

This course provides an introduction to flexible/stretchable electronics. It will cover almost all aspects of flexible electronics, including design, fabrication and application. Specifically, we will discuss: (1) Deposition and processing of thin film materials for flexible electronics, (2) Design and mechanics of flexible/stretchable electronics, (3) Transfer printing for flexible electronics fabrication, (4) Application of flexible/stretchable electronics, and (5) Recent advances in smart electronics, transient electronics and self-healable electronics.

Course instructor(s):

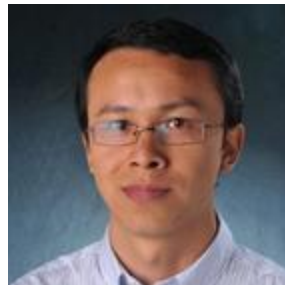

Jianliang Xiao

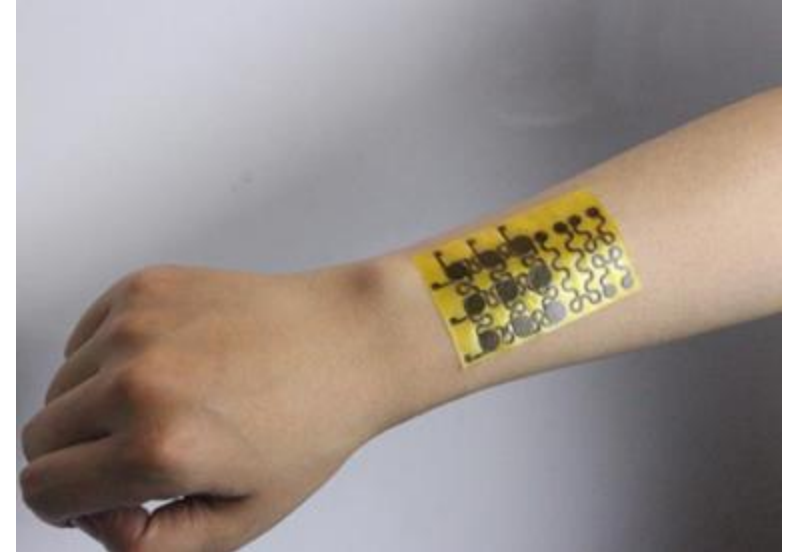

Teaching schedule: Availability varies. Offered as instructor schedules allow.



MCEN 5228: Fracture Mechanics

Career Areas

Product Design
Failure Analysis

Specializations

None

Prerequisites

None

Pre or Corequisites

None

This course will introduce fundamental concepts, analytical approaches, and experimental methods to characterize the fracture of solid materials. Topics to be discussed include: linear elastic analysis of 2D cracks, energy flows and criteria for elastic fracture, experimental methods for elastic fracture, application of fracture mechanics in adhesion, introduction to elastic plastic fracture, and nonlinear fracture mechanics of soft materials.

Course instructor(s):



Rong Long

Teaching schedule: Availability varies. Offered as instructor schedules allow.

Hencky Strain e_{22}

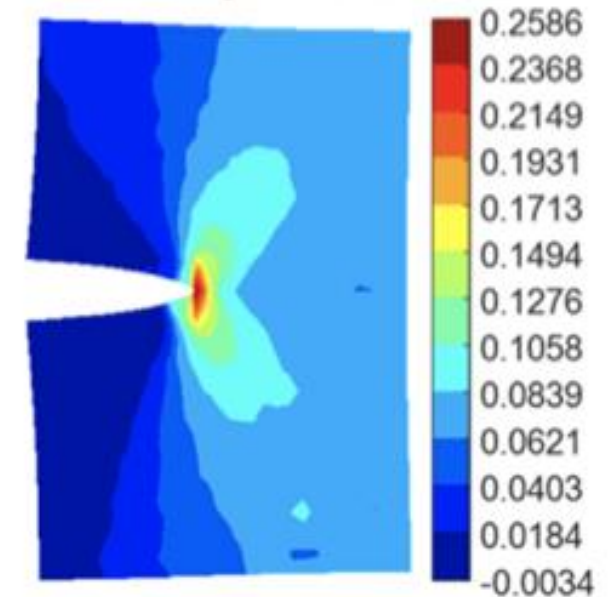

MCEN 5228: Optical Sensing

Career Areas

Laser Diagnostics
Energy/Environment

Specializations

None

Prerequisites

TBD

Pre or Corequisites

TBD

Introduces the fundamentals of optical sensing derived from principles of quantum mechanics and presents practical optical sensing techniques and their applications. Topics include quantized energy levels of molecules, molecular absorption and emission processes, spectral lineshapes, laser-absorption spectroscopy, laser-induced fluorescence, emission spectroscopy, and imaging. Includes practical optical sensing applications from laboratory laser experiments to satellite remote sensing in atmospheric, environmental, and combustion science. The course will include laboratory demonstrations and students will analyze experimental data.

Course instructor(s):



Greg Rieker

Teaching schedule: Availability varies. Offered as instructor schedules allow.

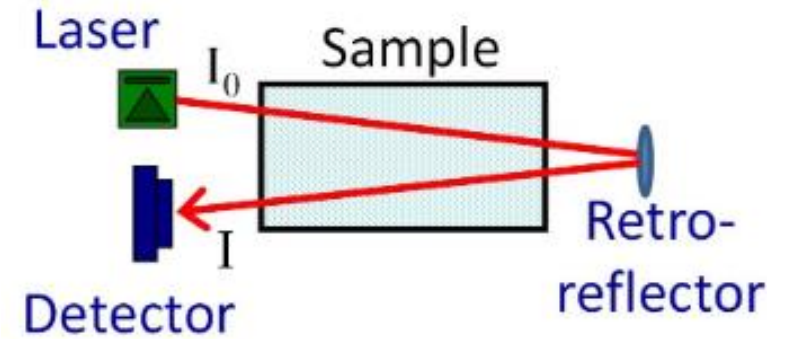

MCEN 4238: Design for Community

Career Areas

Product Design
Project Management
Engineering Consulting

Specializations

None

Prerequisites

None

Pre or Corequisites

None

Design for Community (D4C) will provide engineering students with practical experience in consulting while offering valuable engineering services to University and industry clients. Focuses on preparing students for the practice of engineering by acting as a consultancy for clients' engineering-related design and fabrication needs. Students may be expected to work in teams or individually under the supervision of project directors, depending on project scope. Each student or team will assist several clients during the semester.

Course instructor(s):



Dan Riffell

Teaching schedule: Offered both fall and spring semester.

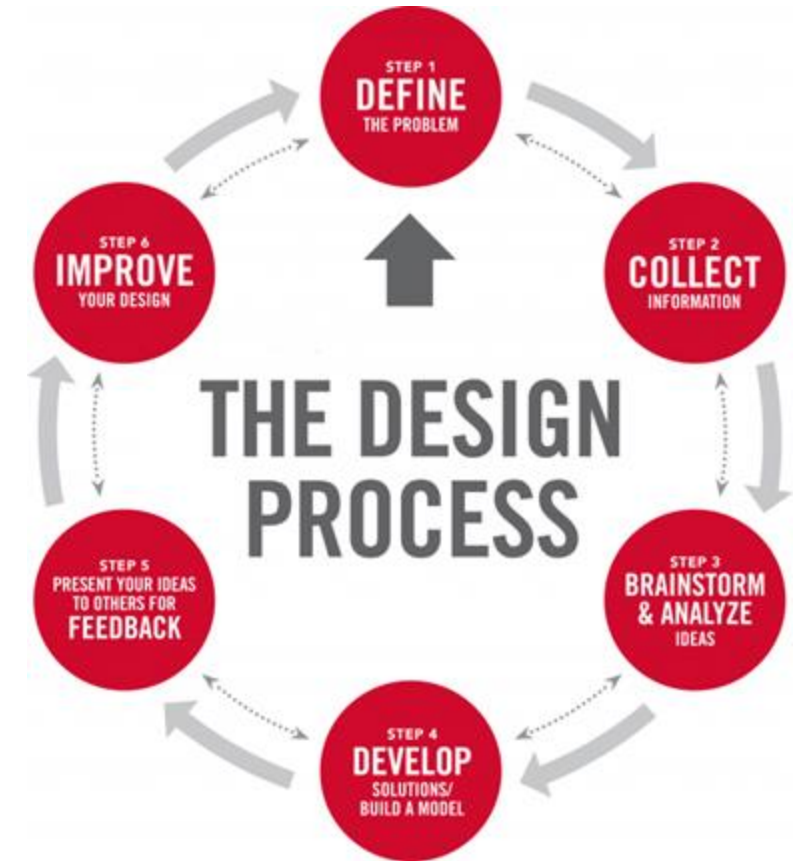

MCEN 4279/5279: Aesthetics of Design

Career Areas

Industrial Design
Design for the Arts
Upcycling

Specializations

None

Prerequisites

None

Pre or Corequisites

None

Focuses on aesthetic aspects of design via hands-on design-build experiences. Students individually create dynamic artifacts of their own choice with the assistance of teammates. Content includes major design movements since 1900, constructive critique practice, hand sketching techniques and other selected industrial design topics. Students publish their design work on an archival public blog which provides a professional portfolio element.

Course instructor(s):



Jean Hertzberg



Stephen Chamot

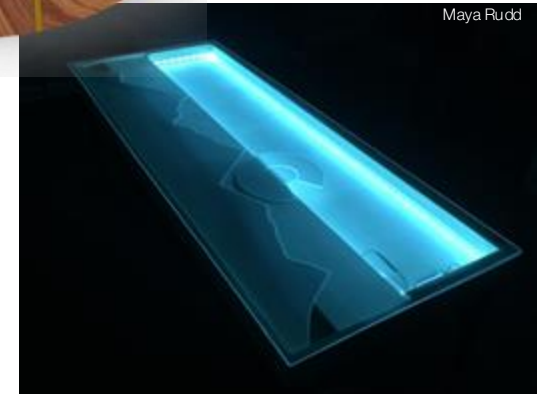

Maya Rudd

Teaching schedule: Generally offered once a year. Availability may vary based on instructor schedule.

MCEN 4291/5291: Project Based Learning in Rural Schools

Career Areas

Education

Environmental Monitoring

Specializations

BS Environmental Option

Prerequisites

None

Pre or Corequisites

None

Focuses on the use of low cost air quality monitoring tools, dubbed Pods, to implement PBL curriculum in high school environmental science classes in rural communities in Colorado. Each student will be paired with a high school class and will serve as curriculum and technology advisors as well as science experts. During the fall semester, students will be trained to effectively work in those roles and will also travel to their schools to be introduced. During the spring semester, students will support high school teachers in implementing an existing PBL air quality curriculum with the Pods. This will include monthly visits to schools in the spring and reporting back to the class.

Course instructor(s):



Daniel Knight



Michael Hannigan



Teaching schedule: Full year course starting in the fall semester. Offered every year.



MCEN 4292/5292: Materials and Devices in Medicine

Career Areas

Biomedical Engineering
Materials Science
Medical Device Design

Specializations

BS Biomedical Option
BS Biomedical Minor

Prerequisites

MCEN 2024: Materials*
MCEN 4117/5117: A&P

Pre or Corequisites

None

*Or equivalent.

The main objective of this course is to provide a broad survey of biomaterials and their use in medical devices for restoring or replacing the functions of injured, diseased, or aged human tissues and organs. The topics to be covered include: evolution in the medical device industry, an introduction to the materials used in medicine, discovery of medical problems, potential impacts of treatment innovations, existing devices and design considerations, materials interaction with the human body, basic mechanisms of wound healing, biocompatibility issues, testing methods, biofunctionalities for specific applications, as well as state-of-the-art approaches for the development of new regenerative materials targeting cellular mechanisms.

Course instructor(s):



Wei Tan

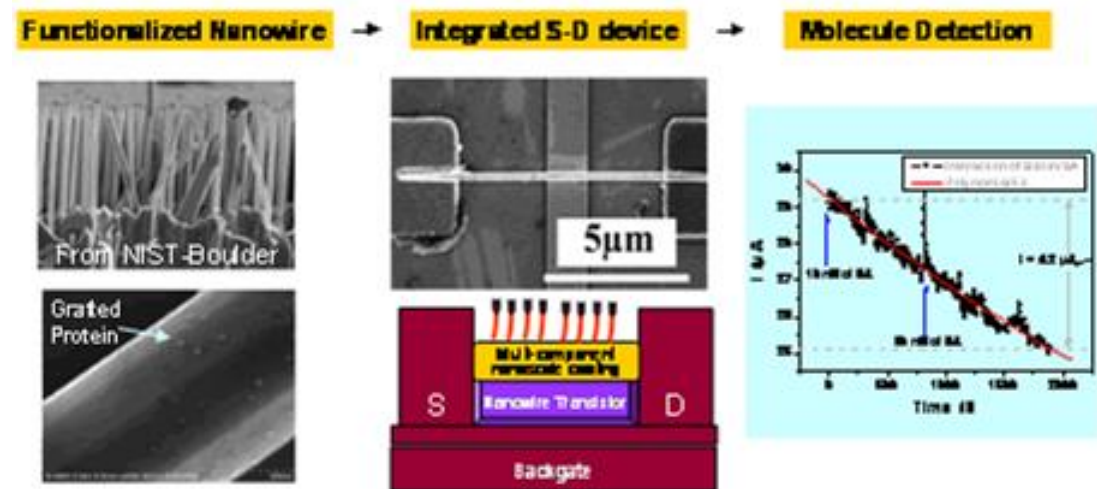

Teaching schedule: Generally offered once a year. Availability may vary based on instructor schedule.

MCEN 4293/5293: Mechanics of Soft Matter

Career Areas

Biomaterials
Biomedical Engineering
Smart Materials

Specializations

BS Biomedical Option
BS Biomedical Minor

Prerequisites

MCEN 2063: Solids*

Pre or Corequisites

None

*Or equivalent.

This class will provide a general overview of fundamental concepts behind the mechanical behavior of soft matter. The term soft matter (which includes polymers, colloids, liquid crystals and surfactants, to name a few) is typically used to describe classes of materials whose structural unit is much larger than atoms, making their response more complex and often richer than that of traditional solids. The objective of this class is to understand how chemical and mechanical forces between these small units yield macroscopic behaviors that one can observe in everyday life. Key engineering applications will also be discussed.

Course instructor(s):



Franck Vernerey

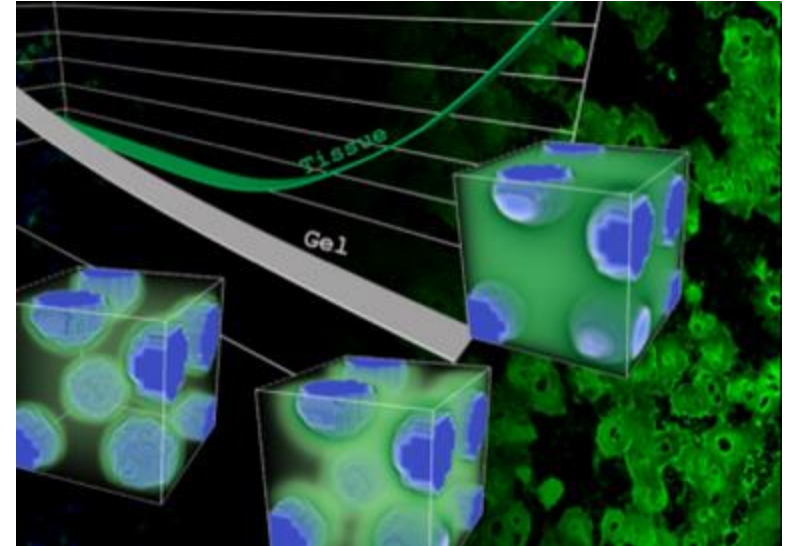

Teaching schedule: Generally offered once a year. Availability may vary based on instructor schedule.

MCEN 4298/5298: Introduction to Polymers

Career Areas

*Design and Manufacturing
Plastic Industry
Chemical Industry
Energy Engineering*

Specializations

None

Prerequisites

MCEN 2024: Materials*

Pre or Corequisites

None

**Or equivalent.*

Polymers represent a major class of engineering materials that are used by mechanical engineers. Yet, very little is covered in current ME curriculum. In this class, we will discuss the most fundamental concepts regarding polymeric materials. Topics include synthesis/manufacturing and chemical properties of polymers, statistical properties of polymer chains, multiphase polymers including polymer solutions and polymer blends, crystallization and glass transition of polymers, and viscoelastic properties of polymers.

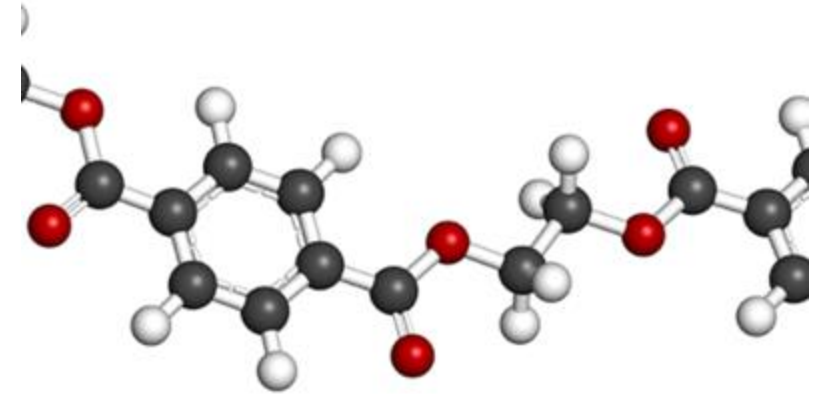

Course instructor(s):



Yifu Ding

Teaching schedule: Generally offered once every two years.



MCEN 4299/5299: Household Energy Systems

Career Areas

Global Engineering

Air Quality

Biofuels

Energy Efficiency

Specializations

BS Environmental Option

BS Energy Minor

Prerequisites

None

Pre or Corequisites

*MCEN 3022: Heat Transfer**

**Or equivalent.*

Cooking, heating and lighting in the developing world often involves inefficient and incomplete combustion of solid or liquid fuels. The Global Burden of Disease Study in 2010, ranked this combustion as the 4th largest risk factor, causing 4 million premature deaths per year. There is a strong societal need to tackle this problem. Students leaving this course will be able to meet this need as they will have the skills to assess existing and new technology used in the developing world for cooking, heating and lighting.

Course instructor(s):



Mike Hannigan



Teaching schedule: Availability varies. Offered as instructor schedules allow.



MCEN 5448: Linear Systems

Career Areas

Robotics
Controls
Modeling
Dynamic Systems

Specializations

None

Prerequisites

APPM 2360: Diff Eq*

Pre or Corequisites

None

*Or equivalent.

Introduces the theory of linear systems, including vector spaces, linear mappings, structure of linear operators, state space descriptions of dynamic systems, stability, controllability, observability, state variable estimation and feedback control methods.

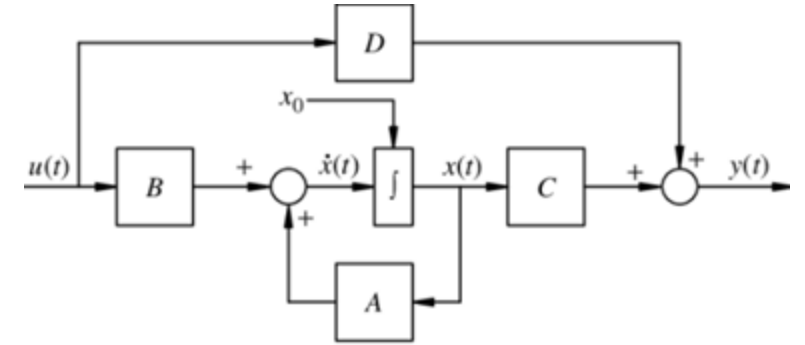

Course instructor(s):



Sean Humbert

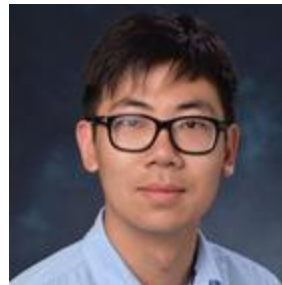

Xudong Chen

Teaching schedule: Offered every fall semester. Taught in alternating years with ECEN.



MCEN 5636: Micro-Electro-Mechanical Systems

Career Areas

Software Development
Electronics Manufacturing
Biomedical Engineering
Robotics/Sensors
Communication Systems

Specializations

None

Prerequisites

ECEN 3010: Circuits*
MCEN 4043: System
Dynamics*

Pre or Corequisites

None

*Or equivalent.

Addresses micro-electro-mechanical systems (MEMS) modeling, design, and fabrication. Focus is on MEMS sensors and actuators due to significance of these devices in optics, medical instruments, navigation components, communications, and robotics.

Course instructor(s):



Victor Bright

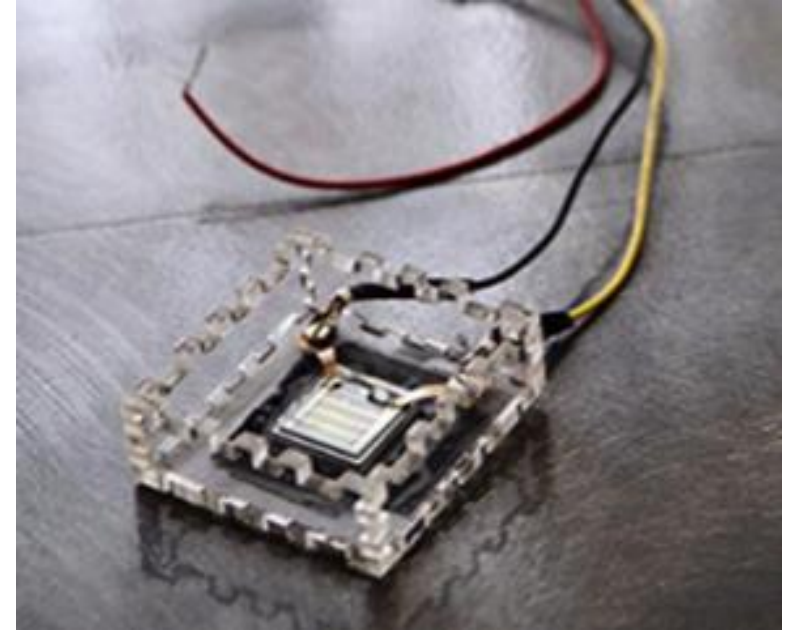

Teaching schedule: Generally offered fall semester. Availability may vary based on instructor schedule.

MCEN 6001: Reacting Flows

Career Areas

Combustion Engines

Gas Turbine Engines

Aerospace Propulsion

Fire Safety

Wildland Fire Modeling

Clean Combustion Biofuels

Emissions Mitigation

Specializations

None

Prerequisites

MCEN 5021: Fluids

Pre or Corequisites

None

Provides an introduction to reacting flows and combustion. Covers chemical kinetics, including global and detailed mechanisms and the variable density flow equations are derived. Relevant non-dimensional parameters and limiting behaviors are discussed. The Rankine-Hugoniot relations are presented and various aspects of diffusion, kinetically dominated and balanced combustion are outlined. Flame structures are discussed, including laminar and turbulent flames, and the Burke-Schumann solution is outlined.

Course instructor(s):



Peter Hamlington



Teaching schedule: Availability varies. Offered as instructor schedules allow.



MCEN 6184: Structures and Properties of Polymers

Career Areas

Materials Science

Specializations

None

Prerequisites

None

Pre or Corequisites

None

Emphasizes the relationship between molecular structure and macroscopic properties. Structural aspects include chain conformation, configuration, and the crystalline and amorphous states. Discusses physical and mechanical properties with a focus on solution and phase behavior, transitions of bulk polymers, and rubber and viscoelastic behavior.

Course instructor(s):



Yifu Ding

Teaching schedule: Generally offered once every two years.

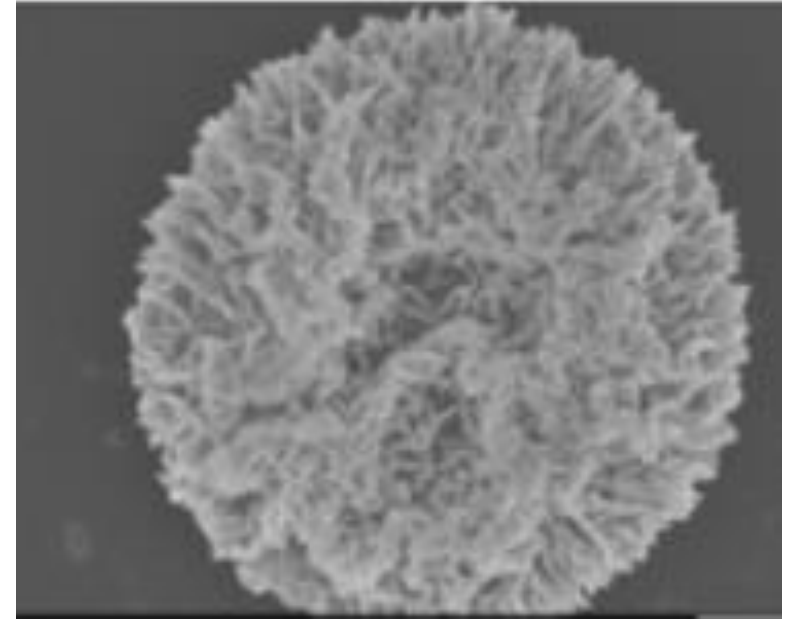

MCEN 6228: Continuum Mechanics

Career Areas

Advanced Mechanics

Specializations

None

Prerequisites

MCEN 5023: Solids

Pre or Corequisites

None

This class will treat of the nonlinear mechanical response of a variety of engineering, biological and bio-inspired materials. We will start by redefining key concepts of solid mechanics in the context of finite deformation and further explore the response of elastic and inelastic solids. In this context, we will discuss the relationship between the micromechanics occurring at the level of a material's structure and the emerging mechanical response during elasticity, viscoelasticity, plasticity, damage and fracture.

Course instructor(s):



Francois Barthelat



Franck Vernerey

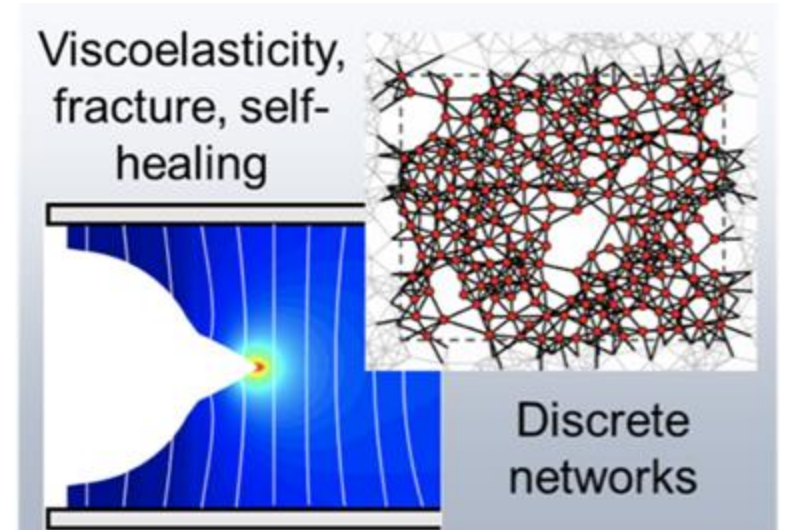

Teaching schedule: Availability varies. Offered as instructor schedules allow.



MCEN 6228: Kinetics of Chemical Systems

Career Areas

Combustion
Pollution Control
Aviation
Chemistry

Specializations

None

Prerequisites

MCEN 5022: Classical
Thermo

Pre or Corequisites

None

Develop an advanced understanding of chemical kinetics in relation to applications for combustion, atmospheric sciences, and catalysis. Understand concepts of molecular bonding as it pertains to chemical reactivity and properties. Learn kinetic theory (transition state theory, master equation theory) and the dependence of reactions on pressure and temperature. Model reacting systems using chemical mechanisms to explore the chemistry of low pressure oxidation, high pressure flame propagation, and molecular growth pathways.

Course instructor(s):



Nicole Labbe

Teaching schedule: Availability varies. Offered as instructor schedules allow.

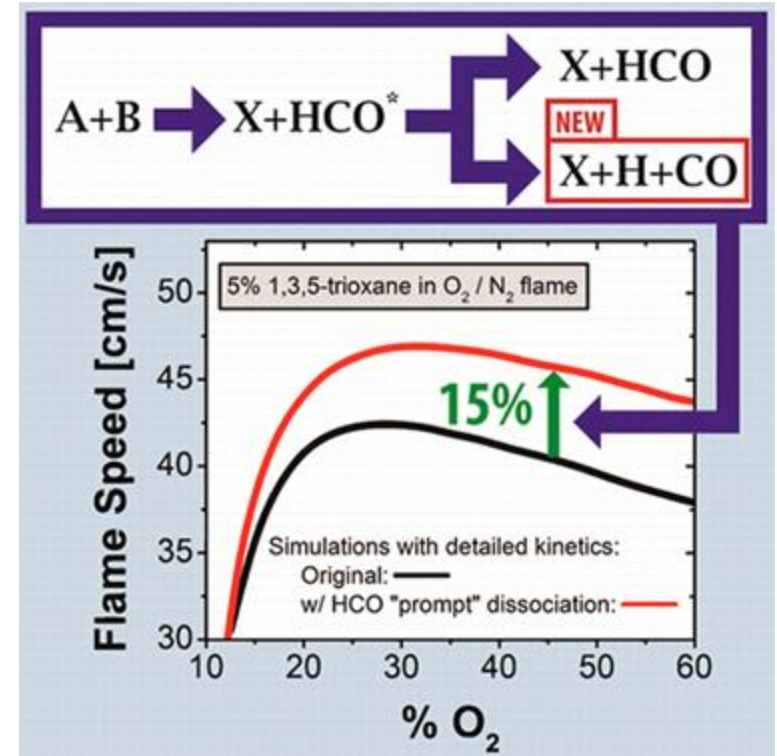

MCEN 6228: Robust Multivariable Control

Career Areas

Controls

Specializations

None

Prerequisites

Graduate Level Knowledge of Controls

Pre or Corequisites

None

Mathematical framework for analysis and synthesis of robust controllers for multivariate, uncertain systems. Singular values, matrix norms, signal and system norms in the time and frequency domain. Loopshaping and generalization of Bode design principles. Uncertainty modeling, linear fractional transformations (LFTs), and the structured singular value. Robust stability and performance, limitations on achievable performance due to uncertainty. Modern synthesis techniques including H- infinity mixed sensitivity and loopshaping design, and mu-synthesis.

Course instructor(s):



Sean Humbert

Teaching schedule: Availability varies. Offered as instructor schedules allow.

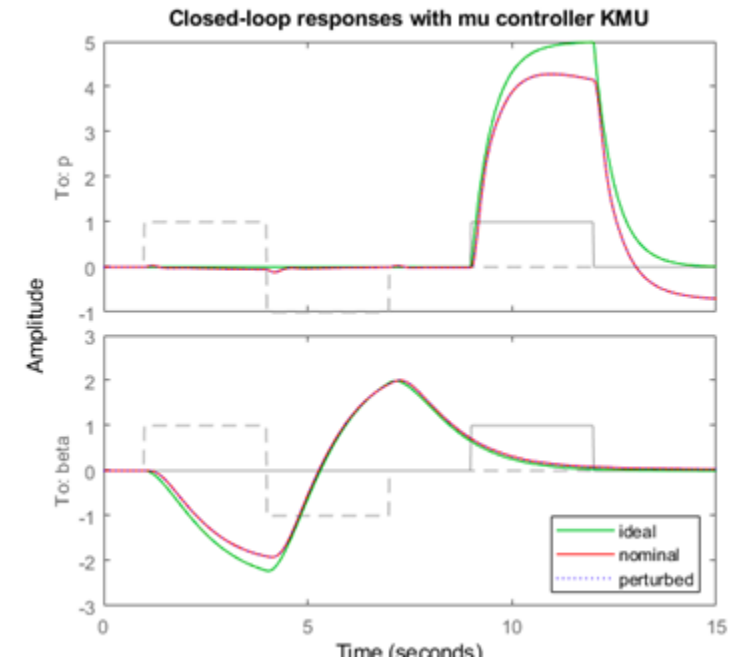

MCEN 6228: Self-Assembling Materials

Career Areas

*Materials Science
Nanoscale/Microscale
Project Management*

Specializations

None

Prerequisites

None

Pre or Corequisites

None

The nano- and microtechnologies that underpin biology (proteins, organelles, and cells) build themselves through “bottom-up” processes of self-assembly and self-organization, in contrast with the “top-down” strategies that characterize engineered nano- and micro-technologies. This course examines both bio-inspired and synthetic approaches to building materials that self-assemble from the bottom up across length scales. Critical review of the current literature in this area will be explored through a combination of discussions, presentations, and proposals.

Course instructor(s):



Carson Bruns

Teaching schedule: Availability varies. Offered as instructor schedules allow.

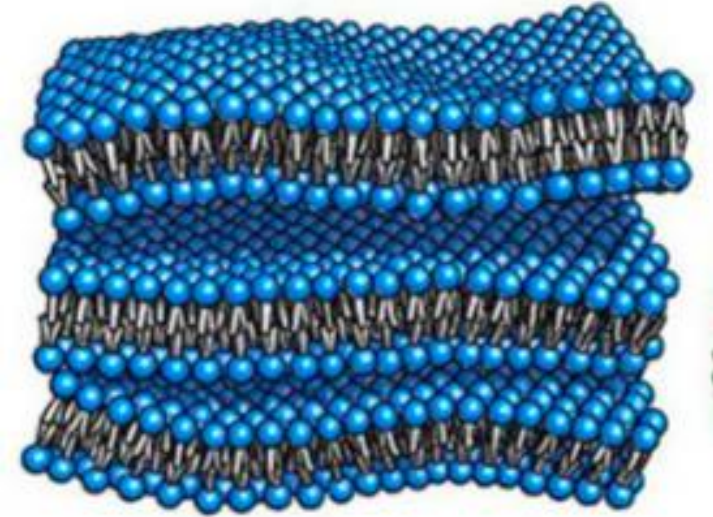

MCEN 6228: Wetting, Adhesion and Friction

Career Areas

Surface Engineering Thin-Film Processing Manufacturing

Specializations

None

Prerequisites

None

Pre or Corequisites

None

This course aims to discuss fundamentals of liquid wetting of a solid surface, adhesion and friction between two contacting surfaces. These interfacial interactions are critical across a broad spectrum of applications from traditional field of rubber tire to emerging areas of designing anti-icing surfaces. The course will examine theories and findings for both conventional materials such as metal and ceramics and more complex soft materials.

Course instructor(s):



Rong Long



Yifu Ding



Teaching schedule: Availability varies. Offered as instructor schedules allow.



MCEN 7221: Turbulence

Career Areas

CFD

Renewable Energy

Combustion

Specializations

None

Prerequisites

None

Pre or Corequisites

None

The material covered in this class includes *(i)* the foundations of high Reynolds number flows and their implications for universal structure in turbulence, *(ii)* the motivations behind a statistical description of turbulent flows, *(iii)* statistical concepts relevant to turbulent flows, focusing on probability density functions, characteristic functions, and correlations, *(iv)* a description of the structure and dynamics of homogeneous, isotropic turbulence, focusing on multi-point statistics, energy-transfer concepts, and their application to the classical problems of turbulence decay and more.

Course instructor(s):



Peter Hamlington

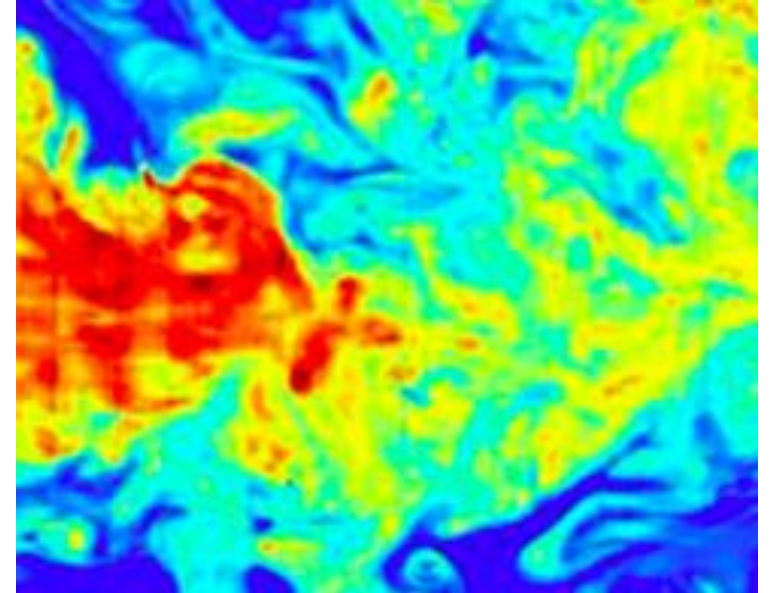

Teaching schedule: Availability varies. Offered as instructor schedules allow.

