

## Section D7090 IT Wireless Communication

### D7090 – Subsections:

- D7090: Introduction
- D7090.11: Wireless Technologies Implementation high level scope
- D7090.12: Wireless Technologies Roles and Responsibilities
- D7090.13: Wireless Technologies Requirements
- Appendices

### **D7090 - Introduction**

Wireless communications are becoming crucial in supporting students, faculty and staff at the University. Different wireless technologies are implemented for different use cases on the campus. Several types of wireless technologies may be designed and deployed during major or minor construction projects on campus.

This section specifies the following:

1. Different types of Wireless technologies that are implemented during University construction projects
2. Roles and responsibilities of all stakeholders
3. Requirements and deliverables in each phase of the wireless technology implementation.

### **Definitions:**

1. **LMR** or Land Mobile Radio is a 2-way push to talk radio system. At the University of Colorado Boulder, OIT has deployed 2 LMR systems where the radios communicate with a trunked infrastructure system comprised of transmitter sites around campus. The first LMR radio system services Public Safety operations for Campus, City, County and State law enforcement. The second LMR radio system provides Business Operations radio coverage for University staff during daily operations and planned events. In addition, the University has also partnered with the City of Boulder to deploy fire fighter radio communications for all campus locations. All LMR systems are fully integrated with the State of Colorado's public safety dispatch system.
2. **Wi-Fi** a.k.a. WLAN is a popular wireless communications protocol that is available on most student and faculty owned computing devices like laptops, tablets and cellphones. Most students and faculty use Wi-Fi to access the internet for learning and social applications in all indoor areas of the campus. Wi-Fi Access points are installed to provide a way for Faculty and Students to connect to the internet.
3. **In-Building Cellular** technologies refers to the various products available in the market that can help improve the indoor performance of cellular services offered by 3<sup>rd</sup> party providers like AT&T and Verizon. Examples of In-Building Cellular technologies include DAS (Distributed Antenna Systems), small cells and femto cells.

### **Advisory for any impacts to building exteriors and site infrastructure:**

Any wireless infrastructure or scope impacting building exteriors, or the campus site, must also involve the Office of the Campus Architect in CU's Office of Planning, Design & Construction.

### **Office of Information Technology's related workgroups and contact information:**

OIT-NEO is Network Engineering and Operations, who provide and approve wireless technology designs and related performance testing. Contact: [OIT-DL-NEO@colorado.edu](mailto:OIT-DL-NEO@colorado.edu)

OIT-VSPI is Voice Services and Physical Infrastructure, who oversee Outside Plant (OSP) data infrastructure, structured cabling infrastructure within buildings, and campus phone services. Contact: [OIT-DL-VSPI@colorado.edu](mailto:OIT-DL-VSPI@colorado.edu)

#### **D7090.11 – Wireless Technologies Implementation high level scope**

1. LMR (Land Mobile Radio system)
  - a. Required: Public Safety LMR coverage in all indoor areas
  - b. Required: Business Operations LMR in all indoor areas
2. Wi-Fi (a.k.a. WLAN – wireless local area network)
  - a. Required: Indoors for all areas including stairways
  - b. Optional: Depending on customer/occupant needs, limited outdoor coverage for social and learning spaces in close proximity to construction site
3. In-Building Cellular technologies
  - a. Optional: Depending on customer/occupant needs

#### **D7090.12 – Wireless Technologies Roles and Responsibilities**

OIT-NEO (Office of Information Technology, Network Engineering and Operations) team  
OIT-Infrastructure

1. LMR Wireless Radio Roles and Responsibilities
  - a. Public Safety LMR
    - i. OIT-NEO in partnership with the City of Boulder will be making an assessment for Public Safety LMR needs based on the project scope
    - ii. Based on the assessment, OIT-NEO may or may not provide a design along with a BOM (Bill of Materials), and/or hardware for the contractor to install
    - iii. After installation, OIT-NEO will validate the install and request certification from the university AHJ
  - b. Business Operations LMR
    - i. OIT-NEO will assess and inform the project team if any additional LMR equipment is needed for this project.
2. Wi-Fi Wireless Networking Roles and Responsibilities
  - a. OIT-NEO will provide the Wi-Fi design in all project scope, even if the project has retained a Technology Consultant. The delivery will be in CAD format. If there is a Technology Design Consultant generating Technology or “T” drawings, Consultant will incorporate OIT-NEO’s Wi-Fi design on their drawing set. If there is no Technology Consultant, OIT will provide T drawings.
    - i. Refer to Appendix **D7090.121** for Wi-Fi design layout Detail (to see an example of this deliverable).
  - b. OIT-NEO will provide Wi-Fi install guidelines/schedule for each Wi-Fi access point as specified in the design.
    - i. Refer to Appendix **D7090.123** for the AP Schedule (to see an example of this deliverable).
  - c. OIT-NEO will provide Wi-Fi Bill Of Materials (BOM) listing all Wi-Fi parts and accessories need for a successful install. This will be delivered in spreadsheet format.

- i. Refer to Appendix **D7090.124** for Bill of Material (to see an example of this deliverable).
    - d. OIT will provide installation requirement drawings based on the Wi-Fi design provided by OIT-NEO.
      - i. Refer to Appendix **D7090.122** for Installation and Mounting instructions (to see an example of this deliverable).
    - e. OIT-Infrastructure will supply all the Wi-Fi parts and Wi-Fi accessories required for the project's low-voltage contractor or Standing Order Contractor (SOC) for Telecom to successfully complete the installation per location.
    - f. Project's low-voltage contractor or SOC for Telecom will install all Wi-Fi equipment, and may request installation support from OIT-NEO during the installation phase.
    - g. OIT-VSPI and OIT-NEO teams will validate the installation performed by the low-voltage contractor or Telecom SOC.
  - 3. In-Building Cellular Roles and Responsibilities
    - a. Based on Customer needs and requirements, during project initiation OIT-NEO will provide recommendation on technology type, design and installation process to the project's Technology Design Consultant (if applicable), architect, and UCB Facilities Management project manager.
    - b. Technology Design Consultant is not permitted to include, recommend or implement any in-building cellular technology for the project without the written consent of OIT-NEO.

### **D7090.13 – Wireless Technologies Requirements**

- 1. LMR Requirements and work breakdown structure
  - a. Public Safety LMR: Wireless Technologies Requirements
    - 1. Design
      - a. Architect or Technology Design Consultant will contact OIT-NEO to start the assessment process
      - b. Architect or Technology Design Consultant will provide OIT-NEO with floor plans and construction materials related to project scope, see Appendix D7090.132: CAD Layers
      - c. OIT-NEO will provide contact information of the LMR engineer assigned to the project
      - d. OIT-NEO will work with CUPD and City of Boulder PD to begin the assessment
        - a. Please note, for new construction projects an assessment can only be made once the building has reached a certain level of completion
      - e. If the assessment indicates poor LMR coverage, OIT-NEO will provide the project team with design, installation and technology recommendations to improve performance
    - 2. Refer to Appendix **D7090.131** for Installation, Post-Installation and Change Management.
  - b. Business Operations LMR: Wireless Technologies Requirements
    - 1. Design
      - a. Architect or Technology Design Consultant will contact OIT-NEO to start the assessment process

- b. Architect or Technology Design Consultant will provide OIT-NEO with floor plans and construction materials related to project scope, see Appendix D7090.132: CAD Layers
        - c. OIT-NEO will provide contact information of the LMR engineer assigned to the project
        - d. OIT-NEO will begin the assessment
          - a. Please note, for new construction projects an assessment can only be made once the building has reached up to a certain level of construction
          - e. If the assessment indicates poor LMR coverage, OIT-NEO will project the project team with design, installation and technology recommendation
      2. Refer to Appendix **D7090.131** for Installation, Post-Installation and Change Management.
    2. Wi-Fi: Wireless Technologies Requirements
      - a. Design
        1. Architect or Technology Design Consultant will provide OIT-NEO with CAD floor plans of the entire scope. CAD floor plans will need to in Autodesk AutoCAD format (2013 dwg format) and should include a layer or callouts indicating:
          - a. Wall types
          - b. Ceiling Types/Heights
          - c. Space designation (learning space, office space, social space)
          - d. Occupancy head count and fire marshal head counts per space
          - e. Refer to Appendix **D7090.132** for AutoCAD Layers to see an example of this deliverable.
        2. Architect or CU Facilities Management Project Manager will need to provide OIT-NEO with a customer point of contact (POC). This can be 1 or multiple POC's that can provide the Wi-Fi performance needs of the various spaces in scope.
        3. OIT-NEO will provide contact information of the Wi-Fi design engineer assigned to the project
        4. OIT-NEO will interview and gather Wi-Fi usage needs from the POC
        5. OIT-NEO will create the Wi-Fi design and provide the deliverables as specified in Section D7090.12 2.a through D7090.12 2.d.
          - a. For more information, please refer to Appendices D7090.121 through D7090.124
        6. The Technology Design Consultant is responsible for importing the Wi-Fi designs into their Technology ("T") drawings, creating and documenting CAD numbers and cable quantity for each location, and updating the Termination Schedule spreadsheet accordingly. See examples in **D7060** IT CAD Requirements **D7060.135** in the appendices for the Termination Schedule example.
      - b. Installation
        1. OIT-Infrastructure will provide the low-voltage contractor with all the Wi-Fi equipment and Wi-Fi accessories necessary for low-voltage contractor to install the equipment per OIT-NEO design and install deliverables

2. OIT will provide the general contractor with detailed installation specifications for every single variation of Wi-Fi AP model, mount and antenna that will be used in the design, to be shared with the low-voltage contractor performing installation.
  3. The project's low-voltage contractor or SOC for Telecom is responsible for ensuring all the Wi-Fi equipment has been installed per the design documents provided by OIT-NEO. If site conditions prevent Wi-Fi equipment from being installed per design, low-voltage contractor/SOC will escalate to OIT-NEO for direction via submitting a Request For Information (RFI).
  4. OIT-NEO and OIT-VSPI will guide the project's low-voltage contractor or SOC for Telecom as needed in complex installation situations, as needed.
- c. Post-Installation
    1. OIT-NEO will validate Wi-Fi installation matched design, and can provide direction for modifications after substantial completion as needed.
  - d. Change Management
    1. The project team must inform OIT if there are any changes in the physical construction (exterior and interior), requirements or change in schedule. Based on the how impactful the change is, OIT-NEO may request a revision of the design requirement process to ensure the right floor plans and construction documents are incorporated into the Wi-Fi design.
3. In Building Cellular technologies: Wireless Technologies Requirements
    - a. There currently are no confirmed requirements for In-Building Cellular technologies. Implementation of this technology will be evaluated on a case by case basis for each construction project. Please refer to section **D7090.12 3** for roles and responsibilities. This section will be updated in the future if a standard technology solution is deemed feasible by OIT-NEO.

**Appendices**

**D7090.121: Wi-Fi design deliverable in CAD format, along with AP mounting index for each Wi-Fi location**

**Example:** CAD deliverable from OIT – Locations can be copied/imported into CD set

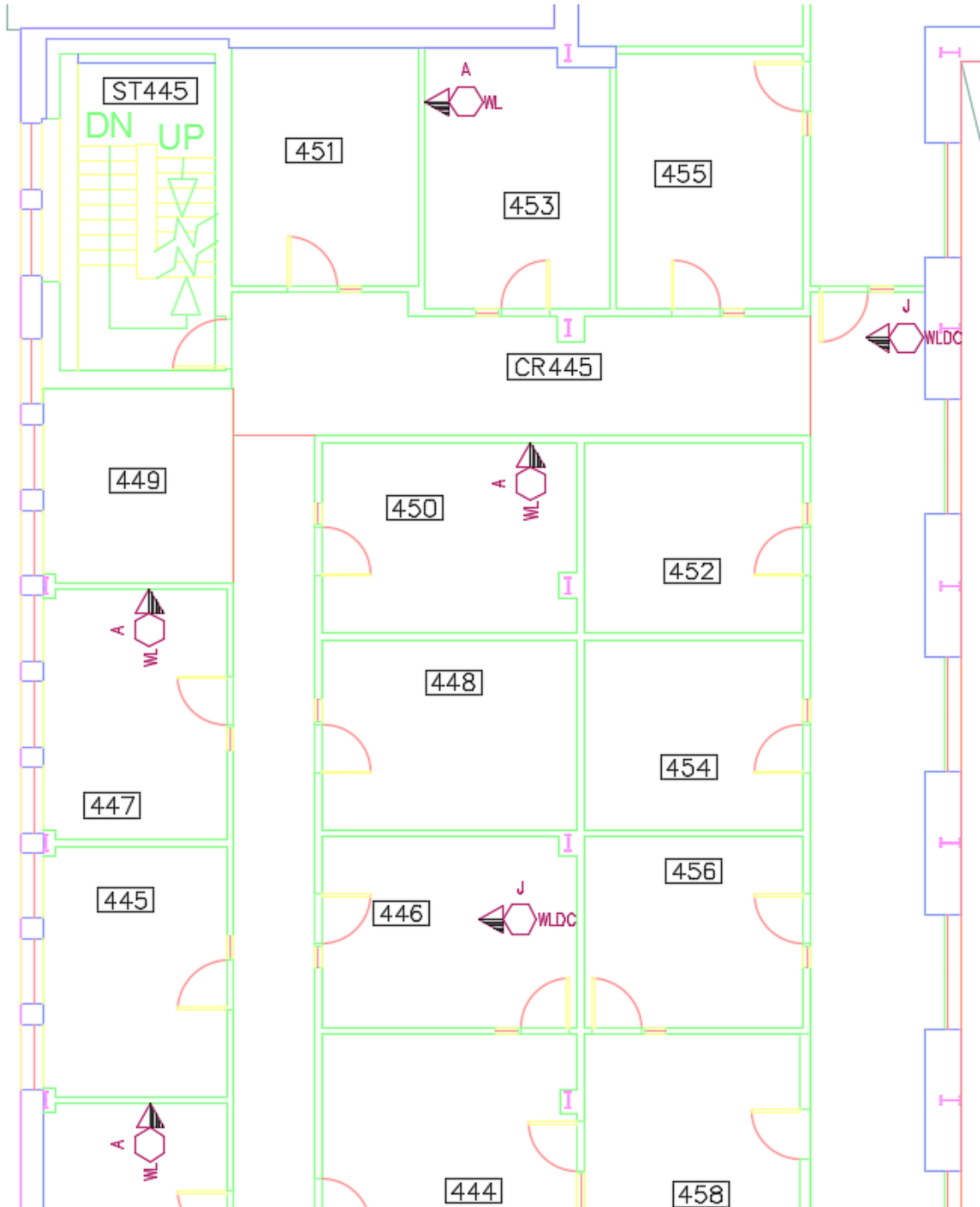

**Example:** Wireless Access Point (WAP) Symbol & AP Mounting Index provided by OIT.

**Attribute Note:** Cable Quantity for each location provided by Architect or Technology Design Consultant.

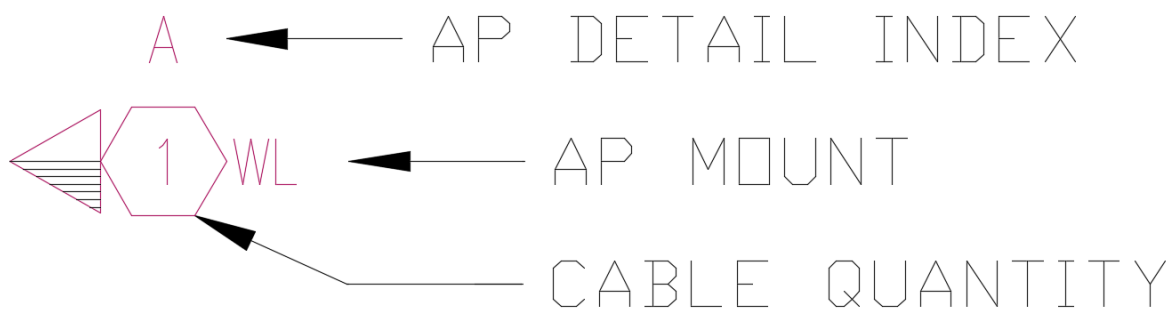

AP mounting Index letter are associated with detail drawings provided by OIT. See example in **D7090.122**.

AP Mounting Index	
A	WL MR-30H HOSPITALITY AP.
B	WLS SURFACE MOUNT ENCLOSURE FOR MR-46, AND MR-46E.
C	WLSX SURFACE MOUNT WITH NO ENCLOSURE FOR THE MR-46 AP.
D	WLP PENDANT MOUNT FOR THE MR-46 AP.
E	WLW RIGHT ANGLE WALL BRACKET FOR MR-46 AP.
F	WLWD WALL DIRECTIONAL INDOORS WITH EXTERNAL ANTENNA AND THE MR-46E AP.
G	WLOS OUTDOOR ANTENNA WITH AN INDOOR MR-46E AP.
H	WLCD CEILING DIRECTIONAL WITH THE AP AND ANTENNA IN THE SAME BOX.
I	WLGM CEILING GRID MOUNT NO ENCLOSURE FOR MR-46 AP.
J	WLDC DROP IN CEILING ENCLOSURE FOR THE MR-46 AP.

**D7090.122: Illustration of deliverable to provide installation and mounting instructions every variation of Wi-Fi infrastructure installed in the project**

**Example:** Detail drawing of Ceiling Grid Mount (WLG) No Enclosure for MR-46. AP Mounting Index Letter in upper right corner (Letter: I).

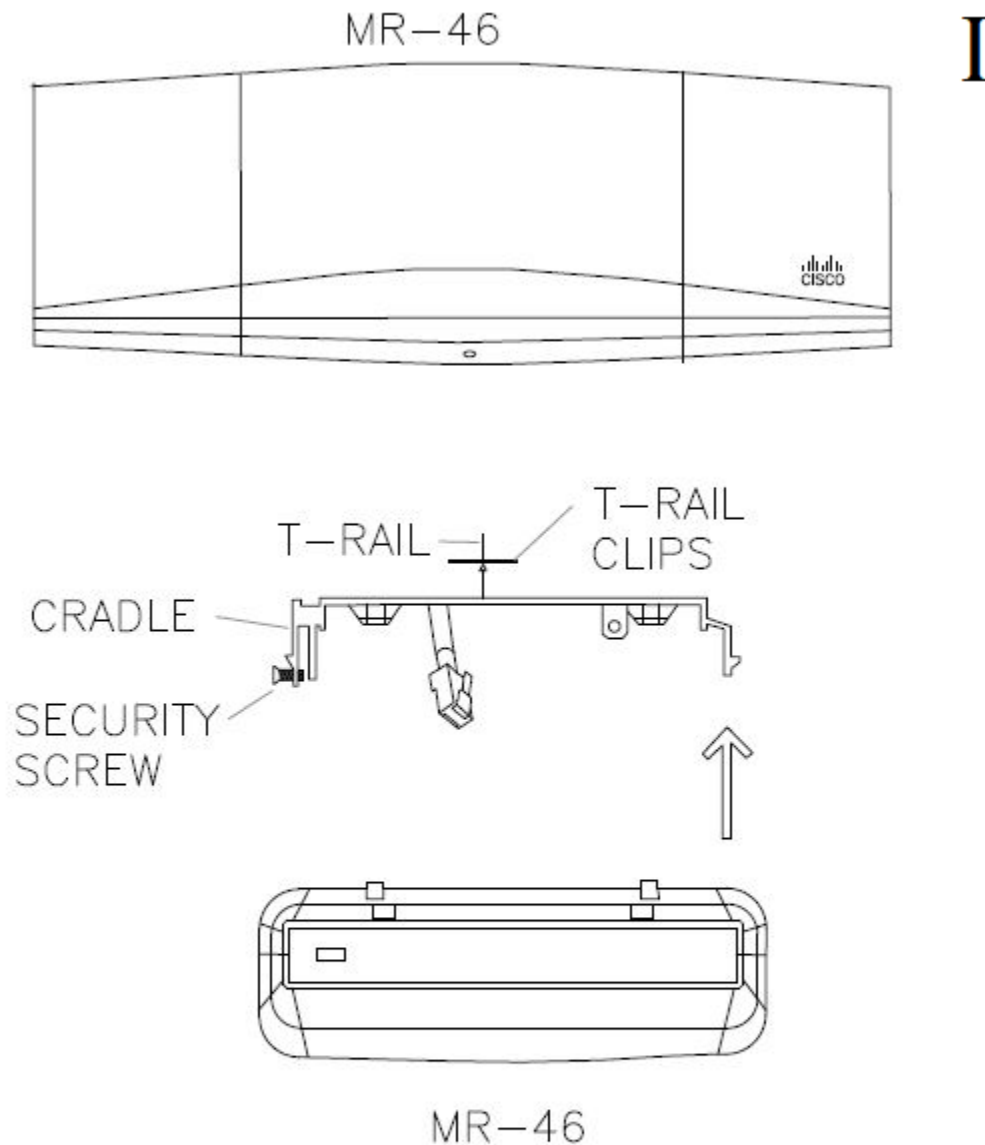

INSTALL THE 6A PATCH CORD INTO THE BACK OF THE AP. ATTACH THE CRADLE TO THE CLIPS ON THE T-RAIL. GUIDE THE MOUNTING TABS ON THE CRADLE INTO THE AP UNTIL IT CLICKS, USE THE SECURITY



**D7090.123: Illustration of AP Schedule/ Installation guideline per each Wi-Fi location in the project scope**

**Example:** AP Schedule – Deliverable provided to show specific attributes of each Wireless Access Point (WAP) location to be inserted into CD.

**Attribute Note:** CAD numbers (CAD#) to be created and filled by Architect or Technology Design Consultant.

AP SCHEDULE																
CAD#	APINDEX	AP-NAME	MOUNT	AP-MODEL	HEIGHT	ROOM#	AP-LOCAL	NEW/EXIST	ANT-MODEL	ANT-TILT-Y	ANT-PIVOT-X	ANT-LOCAL	ANT-CABLE	VENTEV	DBERDN	NOTES
	A	ATLS-150-SW-CL	WL	MR-30H	JACK HEIGHT	ATLS-150	INTERIOR	NEW			N/A		N/A	N/A	N/A	
	B	ATLS-150-SW-CL	WLS	MR-46	CEILING	ATLS-150	INTERIOR	NEW			N/A		N/A	PART#	PART#	
	C	ATLS-150-SW-CL	WLSX	MR-46	CEILING	ATLS-150	INTERIOR	NEW			N/A		N/A	N/A	N/A	
	D	ATLS-150-SW-CL	WLP	MR-46	LEV. WITH LIGHTS	ATLS-150	INTERIOR	NEW			N/A		N/A	PART#	PART#	
	E	ATLS-150-SW-CL	WLW	MR-46	8'-10'	ATLS-150	INTERIOR	NEW			N/A		N/A	PART#	PART#	
	F	ATLS-150-SW-CL	WLWD	MR-46E	10'-12'	ATLS-150	INTERIOR	NEW	MA-ANT-3-E6	-22.5°	CONTACT NE0	INTERIOR	N/A	PART#	PART#	
	G	ATLS-150-SW-CL	WLDS	MR-46E	10'-12'	ATLS-150	INTERIOR	NEW	MA-ANT-3-E6	-22.5°	CONTACT NE0	EXTERIOR	N/A	PART#	PART#	
	H	ATLS-150-SW-CL	WLCD	MR-46E	CEILING	ATLS-150	INTERIOR	NEW	MA-ANT-3-D6	-22.5°	CONTACT NE0	INTERIOR	N/A	PART#	PART#	
	I	ATLS-150-SW-CL	WLGm	MR-46	CEILING	ATLS-150	INTERIOR	NEW			N/A		N/A	PART#	PART#	
	J	ATLS-150-SW-CL	WLDC	MR-46	CEILING	ATLS-150	INTERIOR	NEW			N/A		N/A	PART#	PART#	

**D7090.124: Example of Bill of Materials (BOM) that is provided in each Wi-Fi project. Please note OIT-Infrastructure will provide the actual parts as listed in the BOM.**

**Example:** Bill of Materials (BOM) - OIT Deliverable Showing WAP Totals and Part Numbers for different Mounts in project scope.

BOM						
Count	APIINDEX	MOUNT	AP-MODEL	ANT-MODEL	VENTEV	ØBERØN
1	A	WL	MR-30H		N/A	N/A
1	B	WLS	MR-46		N/A	1022-00
1	C	WLSX	MR-46		N/A	N/A
1	D	WLP	MR-46		TW-HC-MNT/211234 & 231728	900-HC
1	E	WLW	MR-46		564911 & 231728	1011-00
1	F	WLWD	MR-46E	MA-ANT-3-E6	N/A	1022-00
1	G	WLDS	MR-46E	MA-ANT-3-E6	N/A	1022-00
1	H	WLCD	MR-46E	MA-ANT-3-D6	CONTACT NEØ	CONTACT NEØ
1	I	WLGW	MR-46		N/A	N/A
1	J	WLDC	MR-46		V2-ID-CTEN-MR45/229939	1047-MRAP45 or 1047-MRAP45-T
<b>10</b>						

**D7090.131: LMR Installation, Post-Installation and Change Management**

1. Installation
  - a. If the assessment in the design phase requires equipment to be installed, Project's low-voltage contractor or SOC for Telecom will install the equipment as per OIT-NEO design and installation deliverables
2. Post-Installation
  - a. OIT-NEO will validate performance post installation along with CUPD Dispatch and City of Boulder PD
  - b. OIT-NEO will obtain sign off from University Authority Having Jurisdiction (AHJ) for certification of occupancy
3. Change Management
  - a. The project team must inform OIT if there are any changes in the physical construction (exterior and interior), requirements or change in schedule. Based on the how impactful the change is, OIT-NEO may request a revision of the design requirement process to ensure the right floor plans and construction documents are incorporated into the Wi-Fi design.

**D7090.132: CAD Drawings and CAD Layers**

AutoCAD drawings provided to OIT should indicate different wall types/ materials, furniture layout, casework, and equipment layouts of rooms.

CAD Layers should provide OIT Wireless Designers with building info below.

	A	B	C	D
1	Project Name			
2	Project Type			
3	SLNK Project Manager Name			
4	Capital Construction/OIT Project Manager Name			
5	Last date updated			
6	<b>Requirement</b>	<b>Status</b>	<b>Notes (Please add)</b>	<b>Facilitator Point of Contact</b>
7	CADs reflecting current scope of the project			
8	CAD Layer- Wall type - Drywall			
9	CAD Layer- Wall type - Brick			
10	CAD Layer- Wall type - Floor to ceiling glass			
11	CAD Layer- Wall type - Concrete			
12	CAD Layer- Wall type - Lead Lined Walls			
13	CAD Layer- Wall type - Door Layer			
14	CAD Layer- Wall type - Concrete columns			
15	CAD Layer- Wall type - Window Layer			
16	CAD Layer- Wall type - Stairway			
17	CAD Layer- Wall type - Elevator			
18	CAD Layer - Room #			
19	CAD Layer - Room Name			
20	CAD Layer - Mechanical Rooms			
21	CAD Layer - Maximum Capacity per room			
22	CAD Layer - Fire Marshall headcount in hallways and rooms			
23	CAD Layer - Ceiling heights (key if variable)			
24	CAD Layer - Equipment Layout - Mechanical Rooms			
25	CAD Layer - Equipment Layout			
26	CAD Layer - Furniture Layout			
27	CAD Layer - Classroom/Auditorium Seat layout			
28	CAD Layer - Warehouse Racking/Shelving Layout			
29	CAD Layer - Furnance Hood layout			
30	CAD Layer - Fume Hood layout			
31	CAD Layer- Exit Signs			
32	CAD Layer- Sprinkler Heads			
33	CAD Layer - Ceiling decorative layout			
34	CAD Layer/Documentation - wired network jack layout			
35	Documentation - Existing AP layout			
36	Customer Wi-Fi needs Point of Contact			
37	Mechanical Room Wi-Fi needs Point of Contact			
38	Wi-Fi design/location Strategy			Glenn

Example: Original CAD Layers



Example: Modified Layers to indicate Building Materials/Info

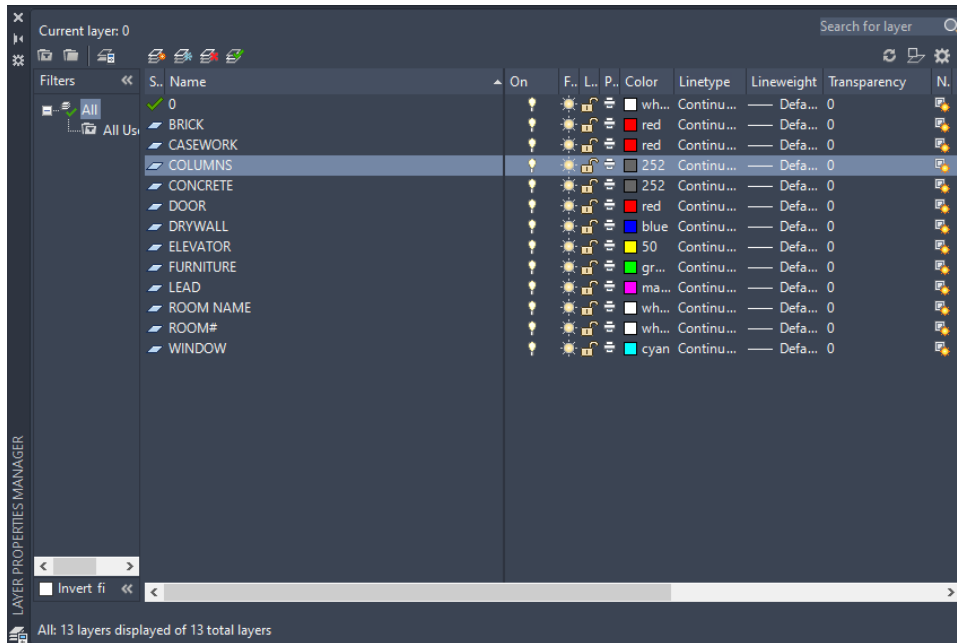

**Other additional CAD Info that will help OIT Wireless Designers:**

- Reflective Ceiling Plans can provide ceiling material and heights for different rooms.
- Maximum occupancy count for rooms in scope of project.