

Section D7020 IT Cabling

D7020 – Subsections:

- D7020: Introduction
- D7020.11: Backbone Cabling General
- D7020.21: Backbone Cabling Materials
- D7020.31: Backbone Cabling Execution
- D7020.41: Horizontal Cabling General
- D7020.51: Horizontal Cabling Materials
- D7020.61: Horizontal Cabling Execution
- Appendices

D7020 - Introduction

This section outlines IT cabling requirements for Information Technology systems in all campus projects.

D7020.11 Backbone Cabling General

This section outlines IT Backbone cabling including both outside and inside copper and fiber. The basic copper guide to be 100 pair copper into the building, and 25 pair copper to each IDF room. The basic fiber guide to be 48 strands of singlemode – 12 stands of 62.5/125 multimode entering the building with 48 strands of singlemode to each IDF room and no multimode to the IDF rooms.

1. Refer to Appendix **D7020.111** for 25pr Tie Cable Termination Detail.

D7020.21 Backbone Cabling Materials

1. Refer to Appendix **D7020.211** for Backbone Cabling Materials.
2. D7020.212 - Inside/Indoor Copper Backbone Cabling
 - a. Plenum-Rated(CMP) Category 3 UTP, 24 AWG
 - i. 25-Pair
 - ii. 50-Pair
 - iii. 100-Pair
3. D7020.213 - Outside Plant (OSP) Copper Twisted-Pair Backbone Cabling
 - a. ASP Filled Core for Buried Installations, 24 AWG
 - i. 25-Pair
 - ii. 50-Pair
 - iii. 100-Pair
4. D7020.214 - Copper Splices
 - a. Refer to Appendix **D7020.2141** for Splice Closure Detail.
 - b. Splice Closure System for use in manholes and tunnels: 2-Type System
 - i. 2-Type Cover
 - ii. 2-Type Endplate
 - iii. Washer Cutter Tool Kit
 - c. Splice Closure System for inside MDFs and IDFs: Split Sleeve Vault & Riser
 - i. Split Sleeve for 200 Pair
 - ii. Split Sleeve for 600 Pair

- d. Provide all required hardware and kits for field splicing in splice closures and for sealing and mounting the closures.
- e. 710 Splice Module – 25 pair splice connector straight/filled with solid cap
- 5. D7020.215 - Inside/Indoor Fiber Optic Backbone Cabling
 - a. Singlemode 8.3/125 Fiber Optic Cable
 - i. 6-Strand Plenum-Rated (OFNP)
 - ii. 12-Strand Plenum-Rated (OFNP)
 - iii. 24-Strand Plenum-Rated (OFNP)
 - iv. 48-Strand Plenum-Rated (OFNP)
 - b. Multimode 62.5/125 Fiber Optic Cable – For Fire Alarm circuits and Existing terminals Only – Coordinated with UCB OIT
 - i. 6-Strand Plenum-Rated (OFNP)
- 6. D7020.216 - Outside Plant Fiber Optic Cable
 - a. Singlemode 8.3/125 Outside Plant Fiber Optic Cable
 - i. 6-Strand Dielectric
 - ii. 12-Strand Dielectric
 - iii. 24-Strand Dielectric
 - iv. 48-Strand Dielectric
 - v. 96-Strand Dielectric
 - b. Multimode 62.5/125 Outside Plant Fiber Optic Cable – With UCB OIT approval only
 - i. 6-Strand Dielectric
 - ii. 12-Strand Dielectric
- 7. D7020.217 - Backbone Fiber Splices
 - a. Fiber Splice Closure:
 - i. Fully equipped with cable addition kit
 - ii. Fiber Optic Splice Tray and all required accessories for a complete installation
 - b. Provide all required hardware and kits for field fusion splicing in splice closures and for sealing and mounting the closures
- 8. D7020.218 - Fiber Connectors and Kits
 - a. LC Connector 0.9 mm for multimode 62.5/125 fiber
 - b. LC Connector 0.9 mm for singlemode fiber
 - c. Pigtails with LC Connectors for multimode 62.5/125 fiber
 - d. Pigtails with LC Connectors for singlemode fiber
 - e. Pigtails with LC-APC Connectors for singlemode fiber
 - f. Breakout Kits for Outside Plant Cable
 - g. Other consumables and kits as required for field termination of fiber optic cable on connectors
 - h. Recloseable fiber storage rings: 12” diameter for inside plant, 24” diameter for outside plant
- 9. D7020.222 - Backbone Cable Installation Materials, Equipment & Tools
 - a. Furnish all required materials, equipment, and tools necessary to properly complete the backbone cabling system installation including, but not limited to: tools for pulling, splicing, and terminating the cables, mounting hardware, cable ties, bolts, anchors, clamps, hangers, kits of consumables, lubricants, communication devices, stands for cable reels, cable wenchers, etc.
 - b. Muletape: Polyester or aramid fiber.
 - c. Conduit Caulking Compound: Compounds for sealing conduit ducts shall have putty-like consistency workable with the hands at temperatures as low as 35 degrees Fahrenheit, shall not slump at a temperature of 300 degrees Fahrenheit, and shall not harden materially when exposed to the air. Compounds shall readily caulk or adhere to clean surfaces of plastic conduit, metallic conduits, or conduit coatings; concrete, masonry; any cable sheaths, jackets, covers, or insulation material, and the common metals. Compounds shall form a seal without dissolving, noticeable

changing characteristics, or removing any of the ingredients. Compounds shall have no injurious effect on the hands of workers or upon materials.

- d. Cable Ties
 - i. Heavy duty nylon cable ties for cable support inside and to unistrut racking within tunnels and crawlspaces
- e. Fiber cable marker tags
- f. "Caution Fiber" labels

D7020.31 – Backbone Cabling Execution

- 1. D7020.311 - Backbone Cabling Installation
 - a. Perform all backbone cable installation in conformance with manufacturer's installation guidelines.
 - b. Ensure that maximum pulling tensions of specified cables are not exceeded and cable bends maintain the proper radius during placement.
 - c. Failure to follow appropriate guidelines for cable installation will require the Contractor to provide, in a timely fashion, the additional material and labor necessary to rectify the situation. This shall apply to any and all damages sustained to the cables during installation.
 - d. Field verify all cable measurements and install all backbone cables in such a manner as to avoid any and all mid-span splices. No mid-span splices are allowed except as specified and shown on project drawings.
 - e. Pull new Muletape through all conduit while pulling new backbone cable.
 - f. The Contractor shall be responsible for all damage to the cable during placement.
 - g. All new cables shall be supported using ladder cable runway, D-rings, and cable management hardware and shall be neatly dressed-out in the MDFs and IDFs.
 - h. Clamp all new cables at the entrance to the MDFs and IDFs for strain relief.
 - i. Do not roll or store cable reels without an appropriate underlay.
 - j. Clamp all new backbone cables at the entrance facilities for strain relief.
 - k. Backbone telecommunications cabling shall be placed in dedicated pathways separate from horizontal and other cabling.
 - l. For copper UTP cable in J-hooks, cable tray, or non-metal pathways, maintain the following clearances from EMI sources:
 - i. Unshielded power lines or equipment less than 5 kVA: 12"
 - ii. Unshielded power lines or equipment equal to or greater than 5 kVA: 24"
 - iii. Power lines enclosed in grounded metal conduit less than 5 kVA: 6"
 - iv. Power lines enclosed in grounded metal conduit equal to or greater than 5 kVA: 12"
 - v. Fluorescent fixtures: 12"
 - vi. Motors or transformers: 48"
 - m. For copper UTP cable in grounded metal pathways (conduit), maintain the following clearances from EMI sources:
 - i. Unshielded power lines or equipment less than 5 kVA: 6"
 - ii. Unshielded power lines or equipment equal to or greater than 5 kVA: 12"
 - iii. Power lines enclosed in grounded metal conduit less than 5 kVA: 3"
 - iv. Power lines enclosed in grounded metal conduit equal to or greater than 5 kVA: 6"
 - v. Fluorescent fixtures: 6"
 - vi. Motors or transformers: 36"
 - n. Backbone cables installed inside buildings, crawlspaces and tunnels shall be strapped to supports or cable racks using heavy duty plastic cable ties.
 - o. Backbone cables in manholes, and all splice cases installed in tunnels, crawl spaces and manholes shall be strapped to the cable racks or manhole steps using stainless steel ties.
 - p. Terminate cables so as not to pull tight on terminating equipment.

- q. Ensure that all splice closures are properly sealed for protection of the cable and splices.
 - r. Neatly and permanently label all backbone cables with the cable number at both ends and at all splice locations.
 - s. Firestop the insides of all sleeves through fire rated barriers after cable installation is complete.
 - t. Plug ends of conduit entering buildings with watertight conduit caulking compound after cable installation is complete to ensure foreign matter does not enter the buildings.
 - u. Test, label, and document the final backbone cable installation, including cable footages, on the as-built drawings. Standard UCB test sheets and labels can be picked up by contacting the UCB OIT Staff.
 - i. Refer to Appendix **D7020.3111** for OSP Cable/Conduit Footage and Count Information sheet.
2. D7020.312 - Copper UTP Backbone Cable
- a. Install copper UTP backbone cabling through conduit, tunnel, and crawl spaces, manholes and other pathways as shown on the drawings.
 - b. Terminate cable pairs on 66M1-50 connecting blocks in the MDF room and IDF rooms shall land in a patch panel. The MDF room shall include a riser from the wall to the patch panel in the MDF relay rack all as shown on the project drawings and following the industry standard color code sequence.
3. D7020.313 - Fiber Backbone Cable
- a. Install fiber optic backbone cable through conduit, tunnel, crawl spaces, manholes and other pathways as shown on the drawings.
 - b. Install fiber storage rings on plywood backboard in MDFs and IDFs as required for project and shown on drawings.
 - c. Install fiber cable service coils, with length of 20 feet, on fiber storage rings, at each end of all new backbone fiber optic cables, to control excess cable lengths, before terminating fiber strands. Each fiber coil shall be Velcro individually for ease of maintenance and repair work. Do not leave fiber cable slack on walls or ladder racks.
 - d. Do not install fiber storage rings and coils on cable or equipment racks. D-rings shall not be used to support the fiber storage rings or coils.
 - e. Place "Caution Fiber" tags at all coils and every 50' along the cable route.
 - f. MDFs and IDFs without fiber coils shall be marks "No fiber coil" on the drawings.
 - g. Fiber schematics for termination of backbone fiber strands in the fiber enclosures will be provided by UCB OIT.
 - h. Terminate fiber strands on connectors or pigtails in fiber enclosures and panels in the MDFs and IDFs, as shown on the project drawings, schematics, and per manufacturer's specifications and color sequence. Splice kits or wallets shall be used within the fiber enclosures to support pigtail splices within fiber enclosures, per manufacturer's specifications.
 - i. Perform termination of multimode fiber strands on ST and LC connectors with loss ≤ 0.5 dB at 850 nm.
 - j. Perform termination of singlemode fiber strands LC connectors with loss ≤ 0.2 dB at 1310 nm
 - k. Do not terminate, splice or cut off "DEAD" cable strands. Neatly coil these unterminated strands inside the fiber enclosure with the proper bend radius to protect them for future termination or splicing.
 - l. Perform fusion splices for multimode and singlemode fiber strands at each splice location with strand numbering as indicated on the drawings.
 - m. Perform fusion splices for singlemode fiber strands and pigtails with splice loss ≤ 0.2 dB at 1310 nm.

- n. Perform fusion splices for multimode fiber strands and pigtails with splice loss ≤ 0.3 dB at 850 nm.

D7020.41 – Horizontal Cabling General

This section outlines IT Horizontal cabling to include one cable for both a voice and data with category 6 cabling. All data drops shall be category 6 except wireless drops of which shall be category 6A and the number of drops shall depend on the in house wireless design.

D7020.51 – Horizontal Cabling – Materials

1. Refer to Appendix **D7020.511** for Horizontal Cabling Materials.
2. D7020.512 - Copper Horizontal Cabling
 - a. Category 6, 4-Pair UTP Cabling
 - i. Plenum Rated (CMP), Green Sheath Color
 1. Outside plant (OSP), Black Sheath Color
 - ii. For Housing Only: Category 6, 4-pair UTP Cabling – For New installations with Ccure reader, Video Cameras, Fire, and Health & Safety
 1. Plenum Rated (CMP), Red Sheath Color
 - iii. Category 6A, 4-Pair UTP Cabling – For special data installation by approval from UCB OIT and all wireless circuits (one cables per wireless Access Point - AP)
 1. Plenum Rated (CMP), White Sheath Color
 2. Outside plant (OSP), Black Sheath Color
3. D7020.513 - Fiber Optic Horizontal Cabling
 - a. Singlemode 8.3/125 Fiber Optic Cable
 - i. 2-Strand Plenum-Rated (OFNP)
 - ii. 6-Strand Plenum-Rated (OFNP)
 - iii. 2-Strand Outside Plant (OSP)
 - iv. 6-Strand Outside Plant (OSP)
 - o. Multimode 62.5/125 Fiber Optic Cable – For Fire Alarm circuits and Existing terminals Only – Coordinated with UCB OIT
 - i. 2-Strand Plenum-Rated (OFNP)
 - ii. 6-Strand Plenum-Rated (OFNP)
 - iii. 2-Strand Outside Plant (OSP)
 - iv. 6-Strand Outside Plant (OSP)
4. D7020.514 - Work Area Faceplates
 - a. Modular Flush-Mount Faceplates
 - i. Single gang with 6 jack openings (holes)
 - ii. Designed for use with modular jacks specified
 - iii. Flat with slots to cover screws and to house white labels and covers
 - iv. Almond or White color as required for project
 - b. MediaFlex Angled Edge Faceplate – For surface raceway installations only
 - i. Single gang with 4 jack openings (holes)
 - ii. Designed for use with modular jacks specified
 - iii. Angled with slots to cover screws and to house white labels and covers
 - iv. Almond or White color as required for project
 - c. Blank Covers for Faceplates
 - i. Designed to fit jack opening in modular faceplate
 - ii. Almond or White color to match faceplate
 - d. Surface Housing for Wireless AP Boxes
 - i. Two-Port for modular outlet jack

- ii. White Color
 - e. Wall Phone Faceplates
 - i. Stainless Steel Recessed Plate with Mounting Lugs
 - f. Floorbox Outlet Frame.
 - g. Floorbox Outlet Faceplate (to be used with outlet frame)
 - h. Single Gang Vertical Faceplate Cover (to secure faceplates at kiosks, laundry, etc.)
 - i. Color Gray, White or Clear per project requirements
 - i. Extension Box for Fiber Jacks with Single-Gang Cut-in or Electrical Box and Mud Ring
 - j. Extra Deep Boxes for Fiber jacks on Flat Surfaces (e.g., inside fire alarm control panel)
- 5. D7020.515 - Copper UTP Modular Jacks for Outlets and Patch Panels
 - a. REVConnect Category 6+, 8-Position, 8-Conductor Jack
 - i. T568B wiring
 - ii. Designed to fit opening in modular connections
 - iii. Blue color
 - iv. Red color for Housing exceptions only on Ccure reader, Video Cameras, Fire, and Health & Safety
 - v. Green color for all Labs as approved from UCB OIT
 - b. Keyconnect Category 6+, 8-Position, 8-Conductor Jack
 - i. T568B wiring
 - ii. Designed to fit opening in modular connections
 - iii. Blue color
 - iv. Red color for Housing exceptions only on Ccure reader, Video Cameras, Fire, and Health & Safety
 - v. Green color for all Labs as approved from UCB OIT
 - c. REVConnect 10GX, for Category 6A, 8-Position, 8-Conductor Jack – For wireless AP and special installations as approved in advance by UCB OIT
 - i. T568B wiring
 - ii. Designed to fit opening in modular connections
 - iii. White color for special data and all wireless circuits.
 - d. Keyconnect Category 6A, 8-Position, 8-Conductor Jack – For wireless AP and special installations as approved in advance by UCB OIT
 - i. T568B wiring
 - ii. Designed to fit opening in modular connections
 - iii. White color for special data and all wireless circuits.
 - e. REVConnect 10GX Field Mount Plug, UTP, Metal.
 - i. T568B wiring
 - ii. Designed to terminate on the end of the station cable
 - iii. For camera locations only.
- 6. D7020.516 - Fiber Connectors and Adapters for Outlets
 - a. LC Duplex Keystone Adapter for Singlemode Fiber
 - i. Designed to fit opening in modular faceplate
 - ii. Blue Adapter
 - iii. Almond or White Housing to match faceplate
 - b. LC Duplex Keystone for Multimode 62.5/125 Fiber
 - i. Designed to fit opening in modular faceplate
 - ii. Beige Adapter
 - iii. Almond or White Housing to match faceplate
 - c. LC-APC Duplex Keystone Adapter for Singlemode Fiber with Angled Polished Connector
 - i. Designed to fit opening in modular faceplate

- ii. Green Adapter
 - iii. Almond or White Housing to match faceplate
 - d. LC Connector 0.9 mm for multimode 62.5/125 fiber
 - e. LC Connector 0.9 mm for singlemode fiber
 - f. Pigtailed with LC Connectors for multimode 62.5/125 fiber
 - g. Pigtailed with LC Connectors for singlemode fiber
 - h. Pigtailed with LC-APC Connectors for singlemode fiber (for DAS)
 - i. Consumables and kits as required for field termination of fiber optic cable on connectors
- 7. D7020.517 - Installation Materials, Equipment & Tools
 - a. Furnish all required materials, equipment, and tools necessary to properly complete the horizontal copper UTP, fiber optic cabling system installation including, but not limited to: tools for pulling and terminating the cables, mounting hardware, cable ties, bolts, anchors, clamps, hangers, kits of consumables, lubricants, communication devices, stands for cable reels, cable wenchers, etc.
 - b. Poly line: poly pull line with a minimum pull tensile strength of 200 pounds.

D7020.61 – Horizontal Cabling – Execution

- 1. D7020.611 - Horizontal Cabling Installation
 - a. Install faceplates with UTP copper and fiber jacks at each work area outlet location as indicated on the project drawings. Place the jacks in the faceplates beginning with position A and placing the copper jacks before the fiber adapter jacks. Place blank covers in the unused openings on each faceplate.
 - b. Faceplates shall be secured with mechanical fasteners. Adhesive fasteners shall not be allowed.
 - c. Install copper UTP, and/or fiber optic horizontal cable from each work area outlet location indicated on the drawings to the MDF or IDF designated on the project drawings.
 - d. Where any portion of the horizontal cable will be routed outside, or under slab, OSP rated cable shall be installed. OSP horizontal cabling shall be fully enclosed in conduit for the entire route from the outlet to the MDF or IDF.
 - e. All horizontal cabling terminating within a single faceplate must be routed to and terminated in the same MDF or IDF.
 - f. Perform all horizontal cable installation in conformance with manufacturer's installation guidelines.
 - g. Ensure that maximum pulling tensions of specified cables are not exceeded and cable bends maintain the proper radius during placement.
 - h. The horizontal cable distribution system design uses conduit, surface raceway, cable tray, and/or J-hooks for support from the outlet location to the MDF or IDF as specified in Section **D7010** and shown on the project drawings. Coordinate as necessary with electrical contractor for placement of horizontal cable pathways and outlet boxes.
 - i. Horizontal telecommunications cabling shall be placed in dedicated pathways separate from backbone and other cabling. The only exception is within cable trays that may have both horizontal and backbone telecommunications cabling separated as far as possible within the trays.
 - j. All horizontal cables within the MDFs and IDFs shall be bundled with Velcro cable every 8 to 12 inches from the patch panels to the point where the cables exit the room. The Velcro cable ties shall hold, but not deform, the cables, and shall overlap a minimum of 2" to allow for more cable to be added in the future. Cable bundles shall have no more than 32 cables per bundle.
 - k. A small drip loop is required on the horizontal cables at the patch panel for trouble shooting and future changes. The drip loop on the horizontal cable should be approximately 2RU from the jack in the panel to the bottom of the loop.

- l. Wireless Access point drops above drop ceilings shall provide 3' service loop above the Wireless Access points, use hook and loop straps to hang loop above the WAP's. The service loop shall not interfere or be supported with other building services such as HVAC, fire alarm, lighting, electrical, etc.
- m. The horizontal cabling routing from each jack on the back of the patch panels shall route to the nearest side of the panel, and shall not cross the center line of the panel. The only exception is for hinged swing-out wall racks, where the horizontal cabling will route from each jack to the hinged side of the panel to allow the rack to swing open for future installations and maintenance.
- n. Install new Poly line in all conduits and cable trays while pulling in new horizontal cables.
- o. Ceiling tile shall be removed as necessary for the cable installation and put back in place without damaging or dirtying any of the tiles or supporting framework. Ceiling tile shall be handled with clean hands so that no fingerprints or marks are left on the tiles. The contractor is responsible for the cost of repair or replacement of any damaged or dirtied tiles or ceiling hardware.
- p. All cables in the ceiling space:
 - i. shall be supported in conduit or in the cable tray and shall not droop or hang outside of cable tray;
 - ii. shall not be run "wild" (unsupported by conduit, cable tray, or J-hooks) for distances greater than four feet;
 - iii. shall not be attached to the suspended ceiling structure or laid directly on the ceiling grid as a means of support;
 - iv. shall not be supported by or attached by any means to fire sprinkler heads or delivery systems, any environmental sensor, or the exterior of any conduit or raceway;
 - v. shall be routed at right angles to the electrical power circuits where the cable is not enclosed in conduit or in cable tray.
- q. Where specifically allowed by UCB OIT, J-hooks shall be specifically designed and installed for the purpose of supporting telecommunications cables. The J-hooks shall be attached to the building structure and framework at a maximum of four-foot intervals. Existing bridle rings may be left in place to support existing cables that are not removed. Bridle rings shall not be used to support new cables.
- r. All cables in J-hooks shall be bundled with plenum rated Velcro cable ties every 8 to 12 inches. The Velcro cable ties shall hold, but not deform, the cables, and shall overlap a minimum of 2" to allow for more cable to be added in the future. Cable bundles shall have no more than 32 cables per bundle.
- s. The total length of any horizontal station cable from the jack location at the outlet to the termination in the MDF or IDF shall not exceed 290 feet. Where building or infrastructure conditions prohibit meeting this requirement, notify the OIT Construction Manager (CM) and Consultant immediately for resolution.
- t. Manage slack for the entire horizontal cable run to avoid excess cable or kinking.
- u. For copper UTP cable in J-hooks, cable tray, or non-metal pathways, maintain the following clearances from EMI sources:
 - i. Unshielded power lines or equipment less than 5 kVA: 12"
 - ii. Unshielded power lines or equipment equal to or greater than 5 kVA: 24"
 - iii. Power lines enclosed in grounded metal conduit less than 5 kVA: 6"
 - iv. Power lines enclosed in grounded metal conduit equal to or greater than 5 kVA: 12"
 - v. Fluorescent fixtures: 12"
 - vi. Motors or transformers: 48"
- v. For copper UTP cable in grounded metal pathways (conduit), maintain the following clearances from EMI sources:
 - i. Unshielded power lines or equipment less than 5 kVA: 6"

- ii. Unshielded power lines or equipment equal to or greater than 5 kVA: 12"
 - iii. Power lines enclosed in grounded metal conduit less than 5 kVA: 3"
 - iv. Power lines enclosed in grounded metal conduit equal to or greater than 5 kVA: 6"
 - v. Fluorescent fixtures: 6"
 - vi. Motors or transformers: 36"
 - w. Do not splice or bridge tap the horizontal cable.
 - x. All cables shall be tied and dressed neatly with a minimum bend radius of 10 times the cable diameter. Provide necessary hardware to maintain proper bend radius at corners.
 - y. All cables shall be firmly held in place. Fastenings and supports shall be adequate to support loads with ample safety factors.
 - z. Failure to follow appropriate guidelines for cable installation will require the Contractor to provide, in a timely fashion, the additional material and labor necessary to rectify the situation. This shall apply to any and all damages sustained to the cables during installation.
 - aa. The Contractor shall be responsible for all damage to the cable during placement.
 - bb. Cables with jackets that are chaffed or burned exposing internal conductor insulation or have any bare copper (shiners) shall be replaced.
 - cc. Do not roll or store cable reels without an appropriate underlay.
 - dd. Firestop the insides of all sleeves through fire rated barriers with a UL approved system after cable installation is complete.
 - ee. Test, label, and document final horizontal cable installation including outlet numbering on as-built drawings.
 - ff. Remove existing cable and terminations that will no longer be used as specified and shown on project drawings. Coordinate as necessary with electrical contractor for removal of existing horizontal cable pathways and outlet boxes.
 - gg. A single gang vertical cover shall be installed for securing voice and data patch connections at such locations as kiosks, as shown on the project drawings. The cover shall be drilled out allow a UCB padlock to be installed.
 - hh. MediaFlex Angled Edge Faceplates shall be installed in service raceways with limited clearance to allow for bend radius requirements from Belden.
2. D7020.612 - Copper Cable Termination
- a. Terminate all pairs on both ends of the copper UTP horizontal cable on the jack with TIA T568B pin-pair assignments per manufacturer's guidelines.
 - b. All cables shall be terminated so as not to pull tight on the terminating equipment.
3. D7020.613 - Inside/Indoor Fiber Optic Horizontal Cabling
- a. Perform termination of multimode fiber strands on LC connectors with loss ≤ 0.5 dB at 850 nm.
 - b. Perform termination of singlemode fiber strands LC connectors with loss ≤ 0.2 dB at 1310 nm
 - c. Perform fusion splices for singlemode fiber strands on pigtails with splice loss ≤ 0.2 dB at 1310 nm.
 - d. Perform fusion splices for multimode fiber strands on pigtails with splice loss ≤ 0.3 dB at 850 nm.
 - e. At the work area outlet, place the LC connectors with terminated fiber cable strands in the keystone adapter jacks in the faceplate.
 - f. Fiber schematics for termination of horizontal fiber strands in the fiber enclosures will be provided by UCB OIT.
 - g. In the MDF or IDF, place the LC connectors with terminated fiber cable strands in the adapter panels in the termination shelf as shown on the fiber schematics and per manufacturer's specifications and color sequence. Splice kits or wallets shall be used within the fiber enclosures to support pigtail splices within fiber enclosures, per manufacturer's specifications.
 - h. All cables shall be terminated so as not to pull tight on the terminating equipment.
4. D7020.614 - General Cabling

- a. Backbone and horizontal station telecommunications cabling shall be placed in separate dedicated pathways. Cable trays shall be clearly divided between backbone and horizontal station cabling.
- b. Telecommunications pathways shall be dedicated for use for OIT voice, data and AV cabling. Other services on OIT cables (intercom, audio, video, security, fire, BAS, DAS, etc.) may be placed in telecommunications pathways only with prior written approval from UCB OIT.
- c. Horizontal cabling for other services may be allowed within the OIT pathways per the following guidelines and acceptance of written approval from OIT. OIT must understand and accept the services to be used on the Horizontal cabling as to not create interference with other services within the pathways. OIT will be the sole owner of the horizontal cabling with jacks on both ends that will be installed and tested per this **D7000** standard. Other terminations and systems can be reviewed by OIT but all Horizontal cabling for other services must be approved in writing from OIT.
- d. All horizontal cabling terminating within a single faceplate must be routed to and terminated in the same MDF or IDF.
- e. Consolidation points and multi-user telecommunications outlet assembly (MUTOA) configurations for horizontal cabling are not currently supported by UCB OIT and will not be permitted.

Appendices

D7020.211 - Backbone Cabling Materials.

Pre-Approved Equipment Schedule

Copper			
Line	Description	Manufacturer	Part Number
1	Outside Copper ASP Filled Core – 25-pair	Superior Essex	22-097-83
2	Outside Copper ASP Filled Core – 50-pair	Superior Essex	22-100-83
3	Outside Copper ASP Filled Core – 100-pair	Superior Essex	22-104-83
4	Outside Copper ASP Filled Core – 200-pair	Superior Essex	22-108-83
5	Outside Copper ASP Filled Core – 300-pair	Superior Essex	22-110-83
6	Outside Copper ASP Filled Core – 400-pair	Superior Essex	22-112-83
7	Outside Copper ASP Filled Core – 600-pair	Superior Essex	22-116-83
8	Outside Copper ASP Filled Core – 900-pair	Superior Essex	22-118-83
9	Outside Copper ASP Filled Core – 1800-pair	Superior Essex	22-124-83
		3M part #	Corning part #
10	Splice closure for manholes & tunnels – 2-type cover	2C2A-510	80611322175
11	Splice closure for manholes & tunnels – 2-type endplate	2C2-1E-510	80611038607
12	Washer Cutter Tool Kit	WCT11K	80611048960
13	Splice closure for inside MDFs & IDFs Split sleeve 200-pair	KBS3-175-1	80611147846
14	Splice closure for inside MDFs & IDFs Split sleeve 600-pair	KBS5-100-6	80611147861
15	710 Splice Module – 25-pair splice connector	3M710-SC1-25	80611048127
		Mohawk part #	Belden part #
16	Inside Copper Backbone Plenum (CMP) – 25-pair	M56801	DPLN25
17	Inside Copper Backbone Plenum (CMP) – 50-pair	M56126	DPLN50
18	Inside Copper Backbone Plenum (CMP) – 100-pair	M56128	DPLN100
Fiber			

Line	Description	Manufacturer	Part Number
19	Nylon Coated Stainless Steel Ties for Splice Cases	Panduit	MLTC Series
20	Locking Nylon Cable Ties	Panduit	PLT6EH-Q
21	Fiber Cable Marker Tags	Panduit	PST-FO
22	“Caution Fiber” Labels	3M	5016-FO
23	Fiber Optic Splice	3M	2178-LS
24	Fiber Optic Splice with cable addition kit	3M	2181-LS
25	Fiber Optic Splice Tray	3M	2522
26	Fiber Storage Ring – Inside Plant 12” Diameter	Leviton	48900-ifr
27	Fiber Storage Ring – Outside Plant 24” Diameter	Leviton	48900-ofr
		CommScope part #	Corning part #
28	Inside Singlemode Fiber Plenum (OFNP) 6-Strand – Mat ID = 760004333	P-006-DS-8W-FSUYL	006E88-31131-29
29	Inside Singlemode Fiber Plenum (OFNP) 12-Strand - Mat ID = 760004358	P-012-DS-8W-FSUYL	012E88-33131-29
30	Inside Singlemode Fiber Plenum (OFNP) 24-Strand - Mat ID = 760018630	P-024-DS-8W-FSUYL	024E88-33131-29
31	Inside Singlemode Fiber Plenum (OFNP) 48-Strand- Mat ID = 760004382	P-048-DS-8W-FMUYL	048E88-33131-29
32	Inside Multimode 62.5/125 Fiber Plenum Riser (OFNP) - 6-Strand Mat ID = 700009525	P-006-DS-6F-FSUOR	006K88-31130-29
33	Outside Singlmode Fiber 6-Strand Mat ID = 760053272	D-006-LA-8W-F06NS	006EU4-T4701D20
34	Outside Singlmode Fiber 12-Strand Mat ID = 760053280	D-012-LA-8W-F12NS	012ZU4-T4F22D20
35	Outside Singlmode Fiber 24-Strand Mat ID = 760053298	D-024-LA-8W-F12NS	024ZU4-T4F22D20
36	Outside Singlmode Fiber 48-Strand Mat ID = 760053314	D-048-LA-8W-F12NS	048ZU4-T4F22D20
37	Outside Singlmode Fiber 96-Strand Mat ID= 760053348	D-096-LA-8W-F12NS	096EU4-T4701D20
38	Outside Multimode 62.5/125 Fiber 6-Strand Mat ID = 760053389	D-006-LA-6F-F06NS	006KU4-T4730D20
39	Outside Multimode 62.5/125 Fiber 12-Strand Mat ID = 760053397	D-012-LA-6F-F12NS	012KU4-T4730D20
40	LC Connector for Multimode 62.5/125 Fiber - Mat ID = 760034181	MFC-LCR-09-BG	95-101-98-SP
41	LC Connector for Singlemode Fiber Mat ID = 760034199	SFC-LCR-09-BL	95-201-98-SP
42	Pigtails with LC Connectors for Multimode 62.5/125 Fiber – 1-Strand (Select Color as appropriate)		FL2-LC-900-OM1-6
43	Pigtails with LC Connectors for Single-mode Fiber 1-Strand (Select Color as appropriate)	FAWLCUC01	FL2-LCU-900-SM-6
44	Pigtails with LC Connectors for Single-mode Fiber 6-Strand color Blue-White =1-6	FAWLCUC0A	
45	Pigtails with LC Connectors for Single-mode Fiber 6-Strand color Red-Aqua = 7-12	FAWLCUC0B	
46	Pigtails with LC Connectors for Single-mode Fiber 12-Strand color Blue-Aqua = 1-12	FAWLCUC0C	
47	APC-LC Connectors for Single-mode Fiber – 1- Strand (Select Color as appropriate)	OCP-L2-02MASEN-XX- YE	95-200-94

48	6-Fiber Breakout Kit – Loose Tube	6 FIBER BREAKOUT KIT Mat ID = 760018820	FAN-OD25-06
49	12-Fiber Breakout Kit – Loose Tube	12 FIBER BREAKOUT KIT Mat ID = 760018838	FAN-OD25-12

D7020.511 - Horizontal Cabling Materials.

Pre-Approved Equipment Schedule

Line	Description	Manufacturer	Part Number
1	Category 6 – Plenum Rated color Green	Belden	2413 005A1000
2	Category 6 – OSP	Belden	OSP6U 0101000
3	Housing, Category 6 – Plenum Rated color Red	Belden	2413 002A1000
4	Category 6A – Plenum Rated color White	Belden	10GXS130091000
5	Category 6A – OSP	Superior Essex	04-601-A4
6	6-port Modular Flush-Mount Faceplate – Almond	Belden	AX102250
7	6-port Modular Flush-Mount Faceplate – Elec. White	Belden	AX102251
8	2-port Modular Flush-Mount Faceplate – Almond	Belden	AX103923
9	2-port Modular Flush-Mount Faceplate – Elec. White	Belden	AX102655
10	4-port Angled Faceplate – Almond	Belden	AX106634
11	4-port Angled Faceplate – Elec. White	Belden	AX106635
12	Blank Covers for Faceplates – Almond	Belden	AX102261
13	Blank Covers for Faceplates – Elec. White	Belden	AX102262
14	Surface Housing for Wireless AP Boxes	Belden	AX104133
15	Wall Phone Faceplates – Stainless steel	Belden	AX104126
16	Floorbox Outlet Frame 6 port – Almond – Decora Adapter	Belden	AX104117
17	4-port Modular Flush-Mount Faceplate Almond – Decora Adapter	Belden	AX103927
18	4-port Modular Flush-Mount Faceplate Elec. White – Decora Adapter	Belden	AX102266
19	Floorbox Outlet Frame 6 port – White – Decora Adapter	Belden	AX104118
20	Single Gang Vertical – Gray	Carlon	E9UVGRN2
21	Single Gang Vertical – White	Carlon	E9UVWRN2
22	Single Gang Vertical – Clear	Carlon	E9UVCRN2
23	Extension Box for Fiber Jacks with Single-Gang Cut-in or Electrical Box and Mud Ring	Wiremold	V5748
24	Extra Deep Boxes for Fiber jacks on Flat Surfaces	Wiremold	V5744
25	REVConnect - Category 6+, 8-Position, 8-Conductor Jack – Blue	Belden	RV6MJKUBL-S1 or RV6MJKUBL-B24

26	REVConnect - Category 6+, 8-Position, 8-Conductor Jack – Red (Housing exceptions only)	Belden	RV6MJKURD-S1 or RV6MJKURD-B24
27	REVConnect - Category 6+, 8-Position, 8-Conductor Jack – Green (Alliance Lab exceptions only)	Belden	RV6MJKUGN-S1 or RV6MJKUGN-B24
28	REVConnect 10GX - Category 6A, 8-Position, 8-Conductor Jack – White	Belden	RVAMJKUEW-S1 or RVAMJKUEW-B24
29	Category 6, 8-Position, 8-Conductor Jack – Blue	Belden	AX104193
30	Category 6, 8-Position, 8-Conductor Jack – Red (Housing exceptions only)	Belden	AX104190
31	Category 6, 8-Position, 8-Conductor Jack – Green (Alliance Lab exceptions only)	Belden	AX104192
32	Category 6A, 8-Position, 8-Conductor Jack – White	Belden	AX102282
33	REVConnect 10GX Field Mounting Plug, UTP	Belden	RVAFPUBK-S1
34	LC Duplex Keystone Adapter for Singlemode Fiber Blue Adapter – Almond Housing	Belden	AX102419
35	LC Duplex Keystone Adapter for Singlemode Fiber Blue Adapter – Electrical White Housing	Belden	AX102420
36	LC Duplex Keystone for Multimode 62.5/125 Fiber Beige Adapter – Almond Housing	Belden	AX102415
37	LC Duplex Keystone for Multimode 62.5/125 Fiber Beige Adapter – White Housing	Belden	AX102416
38	LC-APC Duplex Keystone Adapter for Singlemode Fiber with Angled Polished Connector Green Adapter – Almond Housing	Belden	AX105642-AL
39	LC-APC Duplex Keystone Adapter for Singlemode Fiber with Angled Polished Connector Green Adapter – White Housing	Belden	AX105642-EW
		CommScope part #	Corning part #
40	Inside Singlemode Fiber Plenum (OFNP) 2-Strand	P-002-DS-8W-FSUYL Mat ID = 760004317	002E88-31131-29
41	Inside Singlemode Fiber Plenum (OFNP) 6-Strand	P-006-DS-8W-FSUYL Mat ID = 760004333	006E88-31131-29
42	Outside Singlmode Fiber 2-Strand	D-002-LA-8W-F02NS Mat ID = 760053264	002E8P-31131-29
43	Outside Singlmode Fiber 6-Strand	D-006-LA-8W-F06NS Mat ID = 760053272	006E8P-31131-29
44	Inside Multimode 62.5/125 Fiber Plenum Riser (OFNP) - 2-Strand		002K88-31130-29
45	Inside Multimode 62.5/125 Fiber Plenum Riser (OFNP) - 6-Strand	P-006-DS-6F-FSUOR Mat ID = 700009525	006K88-31130-29
46	Outside Multimode 62.5/125 Fiber 2-Strand		002K8P-31130-29
47	Outside Multimode 62.5/125 Fiber 6-Strand	D-006-LA-6F-F06NS Mat ID = 760053389	006K8P-31130-29

48	LC Connector for Multimode 62.5/125 Fiber	MFC-LCR-09-BG Mat ID = 760034181	95-101-98-SP
49	LC Connector for Singlemode Fiber	SFC-LCR-09-BL Mat ID = 760034199	95-201-98-SP
50	ST Connector for Multimode Fiber 62.5/125	MFC-STU Mat ID = 700004328	95-201-52-SP
51	Pigtails with LC Connectors for Multimode 62.5/125 Fiber – 1-Strand (Select Color as appropriate)		FL2-LC-900-OM1-6
52	Pigtails with LC Connectors for Single-mode Fiber 1-Strand (Select Color as appropriate)	FAWLCUC01	FL2-LCU-900-SM-6
53	APC-LC Connectors for Single-mode Fiber – 1-Strand (Select Color as appropriate)	OCP-L2-02MASEN-XX- YE	95-200-94

D7020.111 - 25pr Tie Cable Termination Detail.

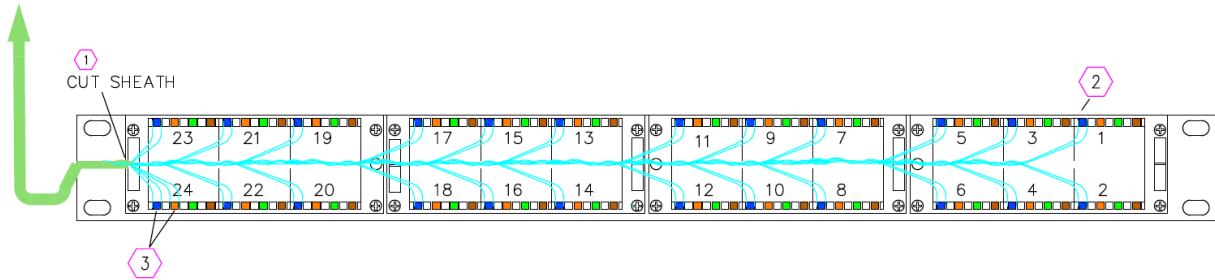

25pr TIE CABLE TERMINATION DETAIL

- ① REMOVE SHEATH AT THE LEADING EDGE OF BLOCK
- ② MAINTAIN TWISTS STARTING IN POSITION #1 AND TERMINATE THE WHITE/BLUE PAIR ON THE BLUE POSITION FOR THE JACK. CONTINUE TERMINATING ONE PAIR FOR EACH POSITION TO #23 FOLLOWING THE COLOR CODE OF A 25PR.
- ③ FOR POSITION #24 TERMINATE THE VIOLET/BROWN ON THE BLUE POSITION FOR THE JACK AND THE VIOLET/SLATE ON THE ORANGE POSITION FOR THE JACK GIVING PORT 24 A (2) PAIR CONNECTION.

D7020.2141 - Splice Closure Detail.

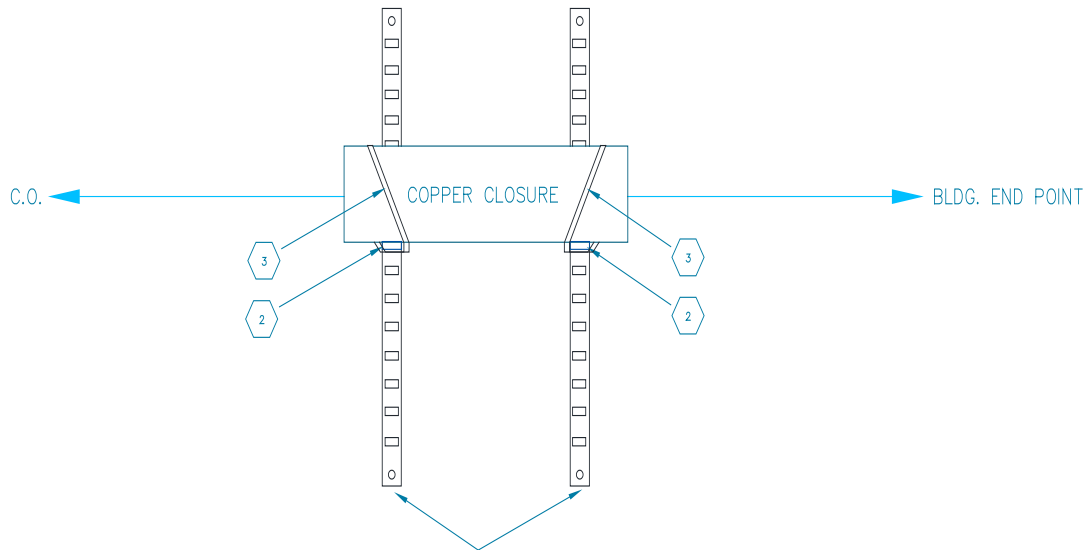



MOUNT 2-18" RACK SUPPORTS 2"
 MIN FROM CLOSURE ENDS.
 USE THE SHORTEST STEPS
 POSSIBLE.

TYPICAL COPPER SPLICE DETAIL

NOT TO SCALE

TYPICAL COPPER SPLICE DRAWING NOTES

- 
 CABLE SHOULD BE SUPPORTED WITH IN 24" OF THE END OF THE SPLICE CASE.
- 
 THE RACK STEPS SHOULD NOT STICK OUT PASSED THE FRONT OF THE CASE (STICK OUT INTO THE TUNNEL) THEY SHOULD BE FLUSH WITH THE FRONT OF THE CASE. YOU MAY NEED TO CUT THEM IF THE ARE TO LONG.
- 
 THE SPLICE CASE SHOULD ALSO BE TIED TO THE STEPS WITH METAL TIE WRAPS.

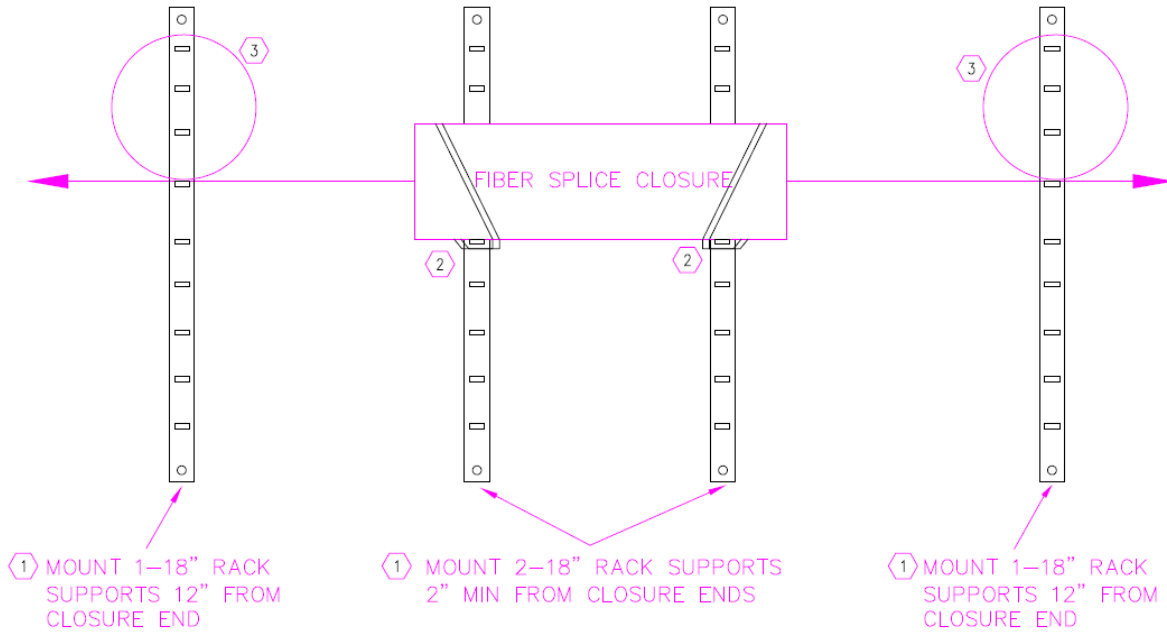

TYPICAL FIBER SPLICE CASE DETAIL

NOT TO SCALE

- ① MOUNT NEW RACKS TO THE WALL AS NEEDED TO SUPPORT THE NEW FIBER SPLICE CLOSURE AND CABLE AS NEEDED.
- ② USE THE RACK STEPS TO SUPPORT THE FIBER SPLICE CASE AND USE HEAVY DUTY TIE WRAPS TO HOLD THE CASE TO THE RACK.
- ③ MOUNT THE 20' SERVICE COILS TO THE RACKS AND ROUTE THE FIBER WITH THE EXISTING CABLES. THESE CABLES SHOULD BE SUPPORTED EVERY 10' TO THE EXISTING CABLE.

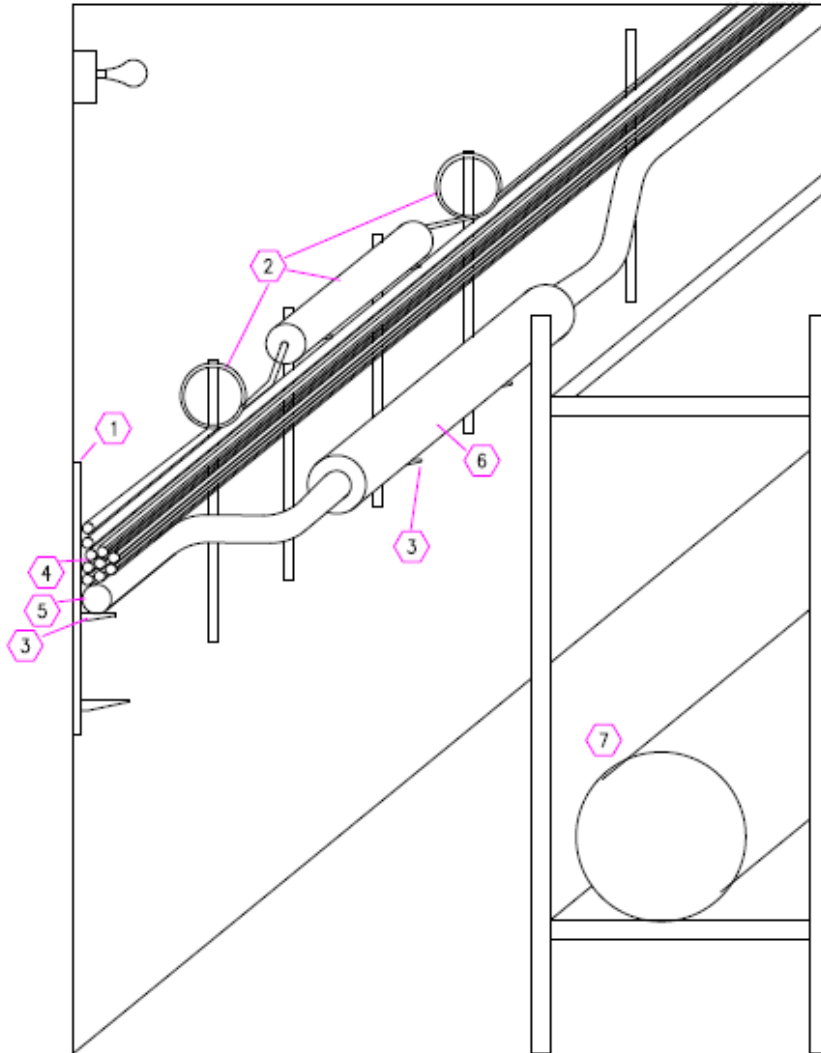

TYPICAL TUNNEL DETAIL

NOT TO SCALE

- 1 WALL RACKS TO SUPPORT CABLE AND SPLICE CASES.
- 2 LOCATION OF FIBER SPLICE CASE ABOVE CABLE PATH AND SERVICE COILS.
- 3 RACK STEPS USED TO SUPPORT THE CABLES TO THE RACKS ALONG WITH USING HEAVY DUTY TIE WRAPS.
- 4 FIBER CABLES ARE THE SMALLER DIAMETER CABLE AND SHOULD BE ROUTED ON TOP OF THE LARGER CABLE. CABLES SHALL BE TIE WRAPPED TO THE RACKS.
- 5 COPPER IS THE LARGER CABLE BETWEEN 600–1800 PAIR. CABLE MUST TO TIE WRAPPED TO THE RACKS TO SUPPORT THE WEIGHT OF THE CABLE AND HAVE RACK STEPS FOR THE CABLE TO REST ON.
- 6 COPPER SPLICE CASES ARE ON THE BOTTOM AND REQUIRE RACK STEPS FOR SUPPORT. THIS CABLE IS STIFFER AND REQUIRES MORE DISTANCE FROM THE CASE TO GET BACK UP TO THE CABLE ROUTING.
- 7 THE STEAM PIPES ARE ON THE OPPOSITE SIDE OF THE TUNNEL AND ARE ON RACKS.

D7020.3111 - OSP Cable/Conduit Footage and Count Information sheet.

Cable Footage and Count Information							
Provide footage in the highlighted boxes.						Project name:	
						Project number:	
						FOR OSP ONLY	
SYM	FOOTAGE	CABLE TYPE	CABLE COUNT	DESTINATION: BUILDING / RISER IDF	TOPO PG	CA BEFORE	CA AFTER