

# PULSAR: Suborbital Flight Validation of LunaSat V8 and Deployment Systems for Distributed Lunar Science Missions

Luke Bassett, Maxx Menzies, Fiona Radebaugh, Jackson Gabbard, Jackson Doyle, Jack Diamond, Curtis Preedom, and the GLEE Team  
University of Colorado Boulder, Colorado Space Grant Consortium

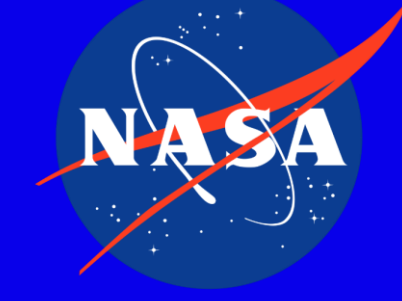

## ABSTRACT

The Payload for Undergraduate Lunar Sensor Assessment of Readiness (PULSAR) Mission is a suborbital rocket experiment validating critical technologies for the Great Lunar Expedition for Everyone (GLEE). PULSAR integrates three primary systems: the LunaSat version eight, a modified Housing and Deployment Module (HDM), and the Satellite Collision Observation and Unified Tracking (SCOUT) orbital debris tracking systems. PULSAR's mission objective is to validate each system in a space environment, advancing the LunaSat v8 to TRL 7, and the HDM and SCOUT systems to TRL 5.

The experiment will be launched in June 2026 through the RockSat-X sounding rocket program at NASA's Wallops Flight Facility, which provides students access to a suborbital flight environment, reaching an altitude of approximately 170 km.

## GLEE MISSION OVERVIEW:

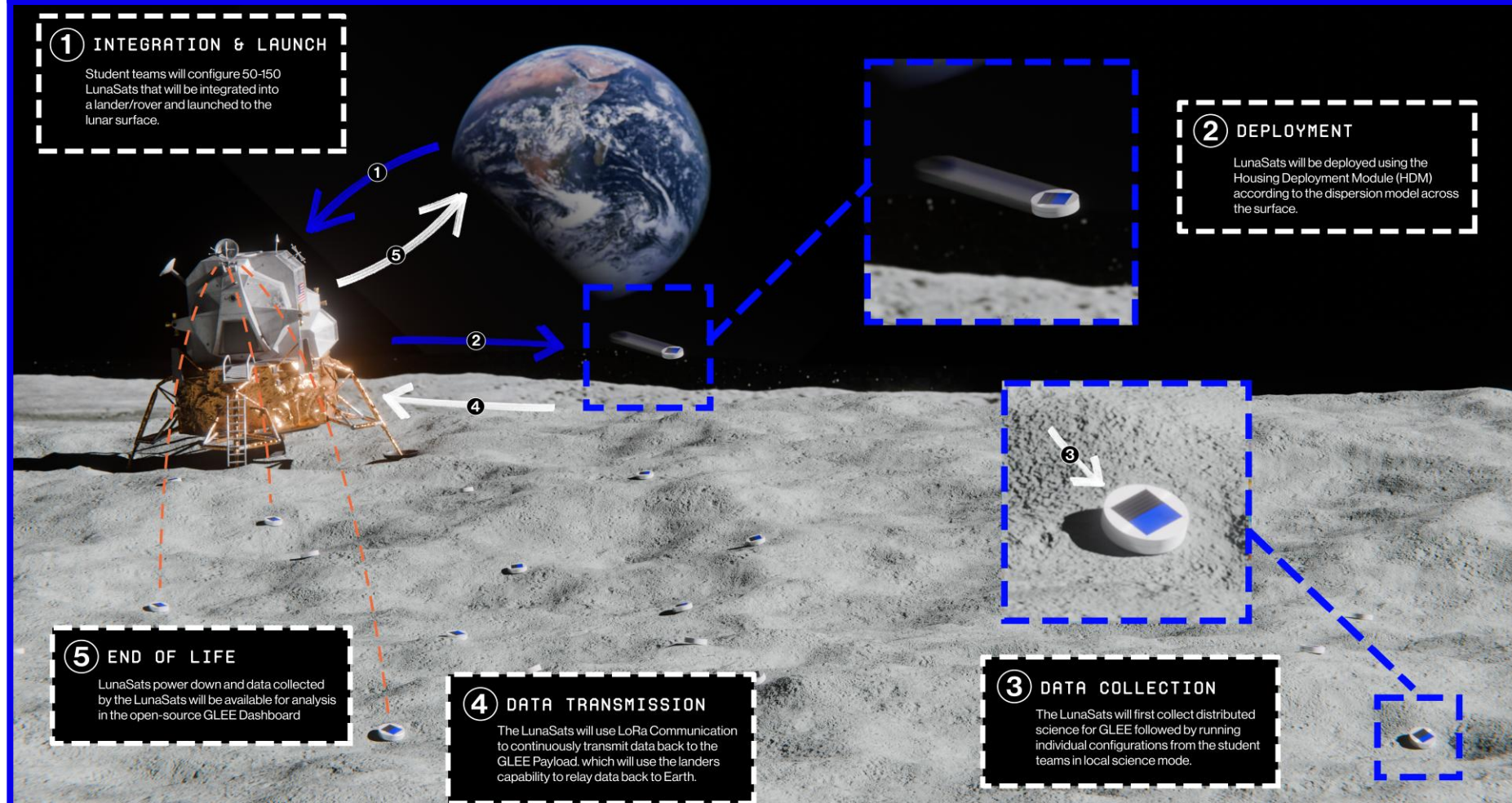

The Great Lunar Expedition for Everyone (GLEE) is a lunar science mission in which small, student-configured sensor platforms called LunaSats are deployed to the lunar surface to conduct distributed science and technology experiments. By engaging students globally in hands-on lunar science, GLEE represents a new model for inclusive, large-scale planetary exploration. PULSAR furthers this vision by validating the LunaSat v8 and GLEE deployment architecture in a spaceflight environment ahead of future lunar missions.

## PULSAR PAYLOAD ENVELOPE:

The PULSAR payload is a flight adaptation of the GLEE HDM designed to comply with RockSat safety constraints and fit within the flat quarter-can volume ( $\varnothing 12" \times 2.316"$ ).

## MOTIVATION FOR ROCKSAT:

Ground testing cannot fully reproduce the microgravity conditions, launch loads, vacuum, and thermal extremes experienced during spaceflight. Suborbital flight provides the opportunity to evaluate LunaSat v8 sensor operation, RF communications, deployment functionality, and structural survivability simultaneously as an integrated system. The RockSat Program provides this environment within a structured, reviewed development framework, making it an ideal platform for advancing the TRL of each PULSAR system ahead of a GLEE lunar mission.

## LUNASAT VERSION EIGHT (V8):

The LunaSat v8 is the latest iteration of the GLEE sensor platform, currently at TRL 6, with PULSAR targeting TRL 7. For RockSat compatibility, v8 design incorporated a battery to ensure reliable power independent of solar panel orientation and killswitches to inhibit activation before deployment per WFF safety requirements.

PULSAR flies three LunaSat v8s: two operating as a mesh network once ejected, and a third retained in the hermetic seal as a redundant baseline via serial in case of RF link degradation. During flight, LunaSats uplink environmental data and RF metrics (RSSI, SNR, and packet loss) to PULSAR avionics for comparison of spaceflight condition operation against ground test baselines.

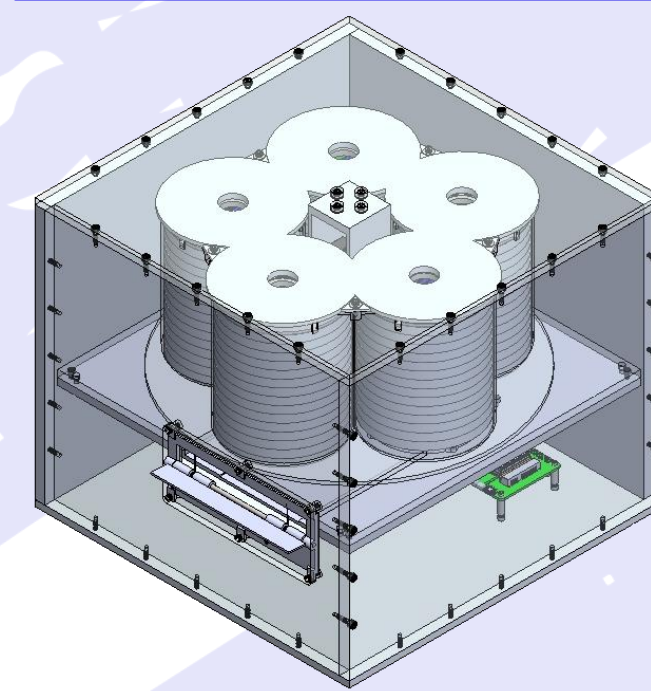
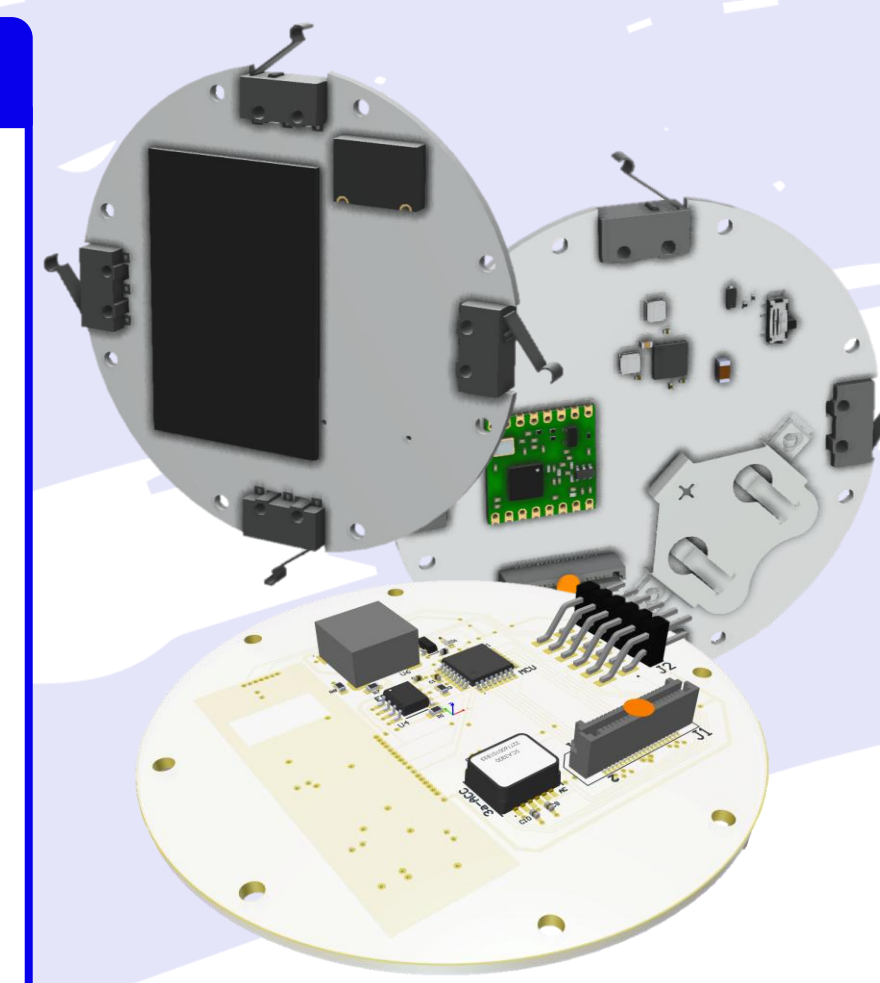

## HOUSING AND DEPLOYMENT MODULE (HDM):

The Housing and Deployment Module (HDM) serves as the structural housing, avionics stack, and deployment system for the LunaSat v8 units. The PULSAR HDM has an adapted architecture for RockSat, deploying LunaSats via a low-velocity push mechanism at  $\sim 10"/s$ . During flight, the avionics stack handles mission events and logs LunaSat data. A successful flight demonstration will advance the HDM to TRL 5 and inform the deployment and communication architecture of future lunar HDM iterations.

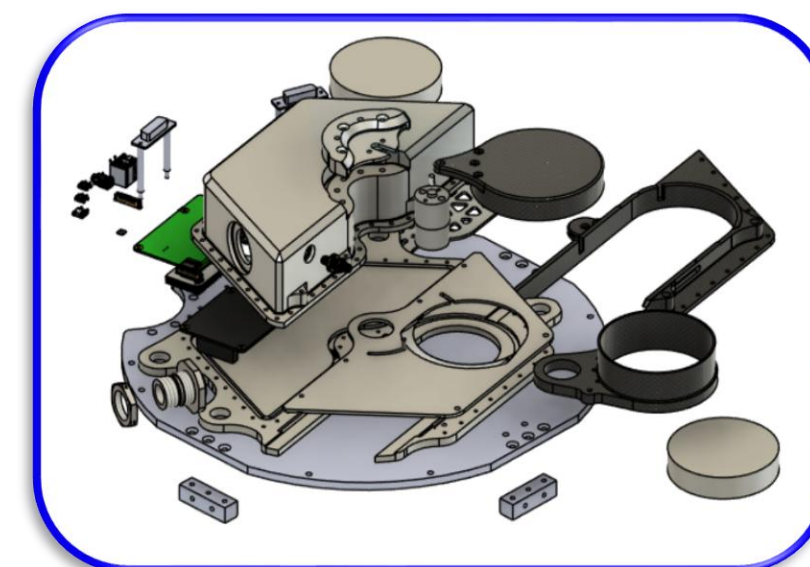
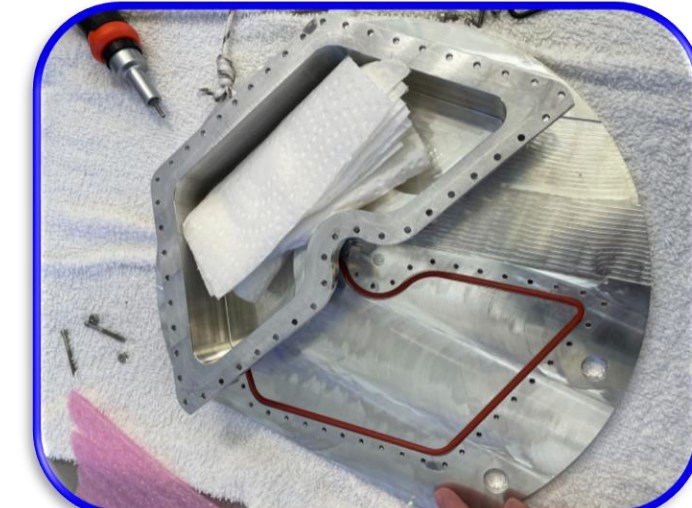
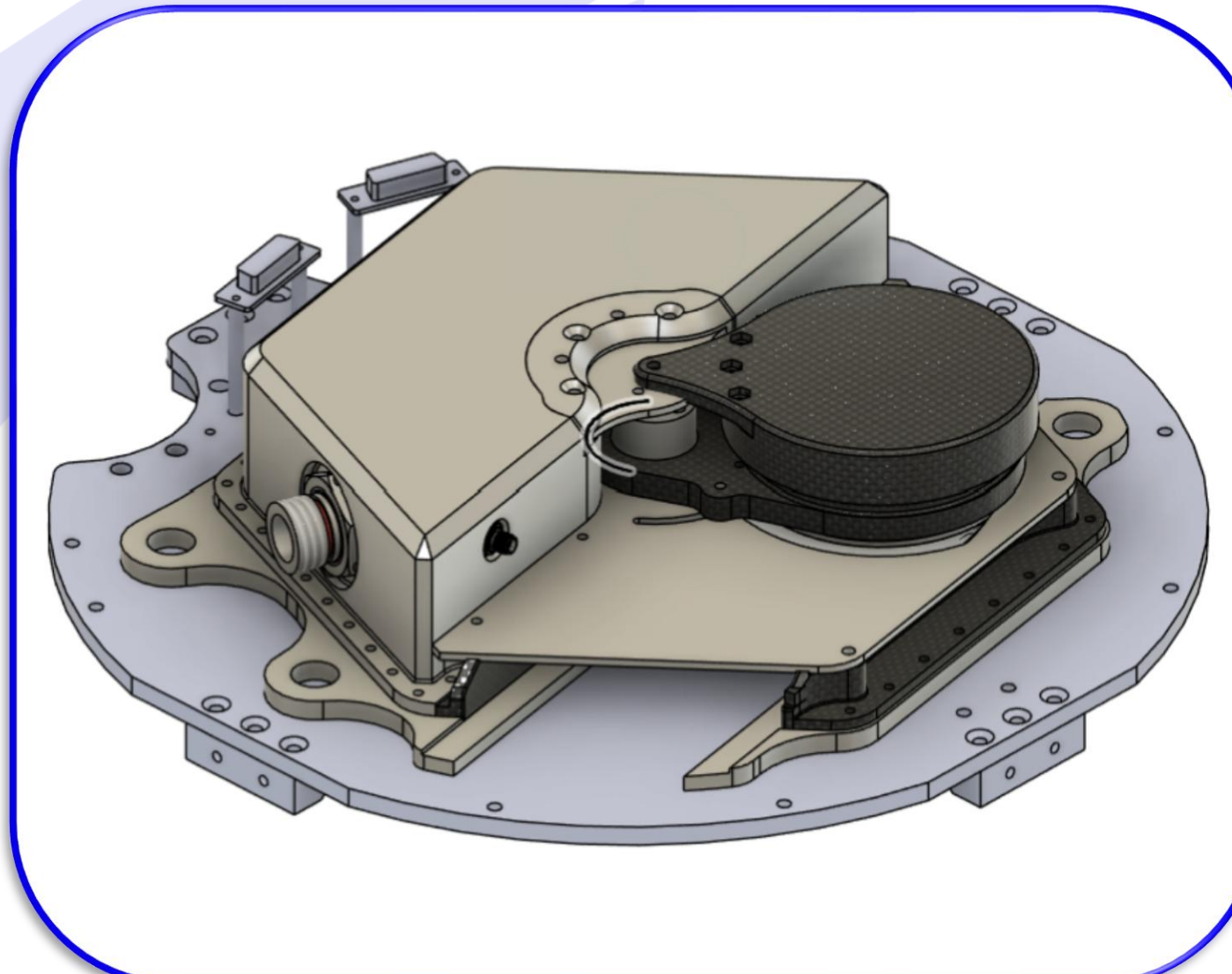

## PULSAR CONCEPT OF OPERATIONS:

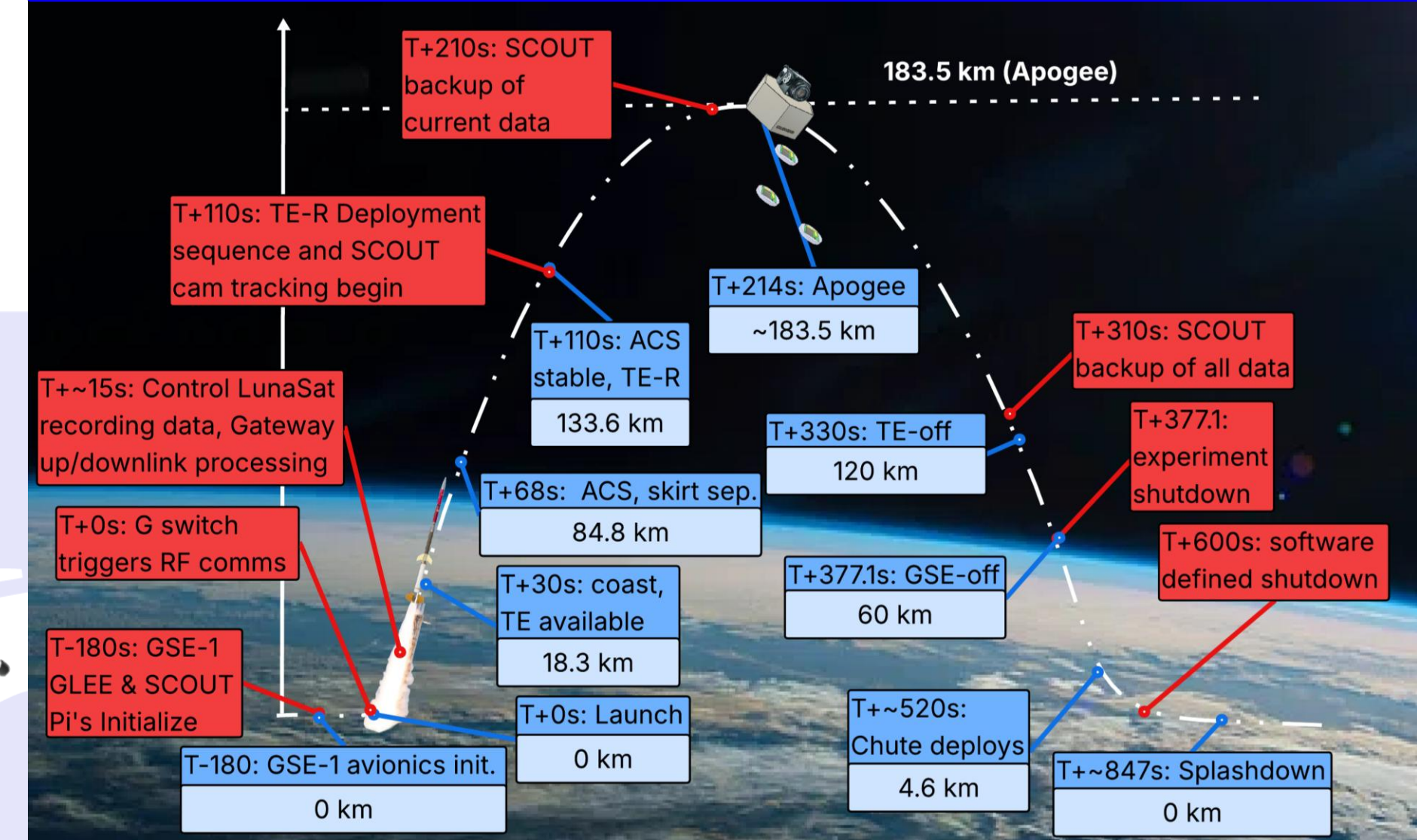

## INTEGRATION AND LAUNCH PREPARATION:

PULSAR is currently completing the RockSat review cycle. Following full system development and verification, PULSAR will integrate to the Terrier-Malamute rocket structure and event-line interface for final testing in May ahead of launch in June. Hydrostatic and dynamic load testing were conducted prior to integration. These processes ensure full payload validation and readiness for flight operations during the RockSat mission.

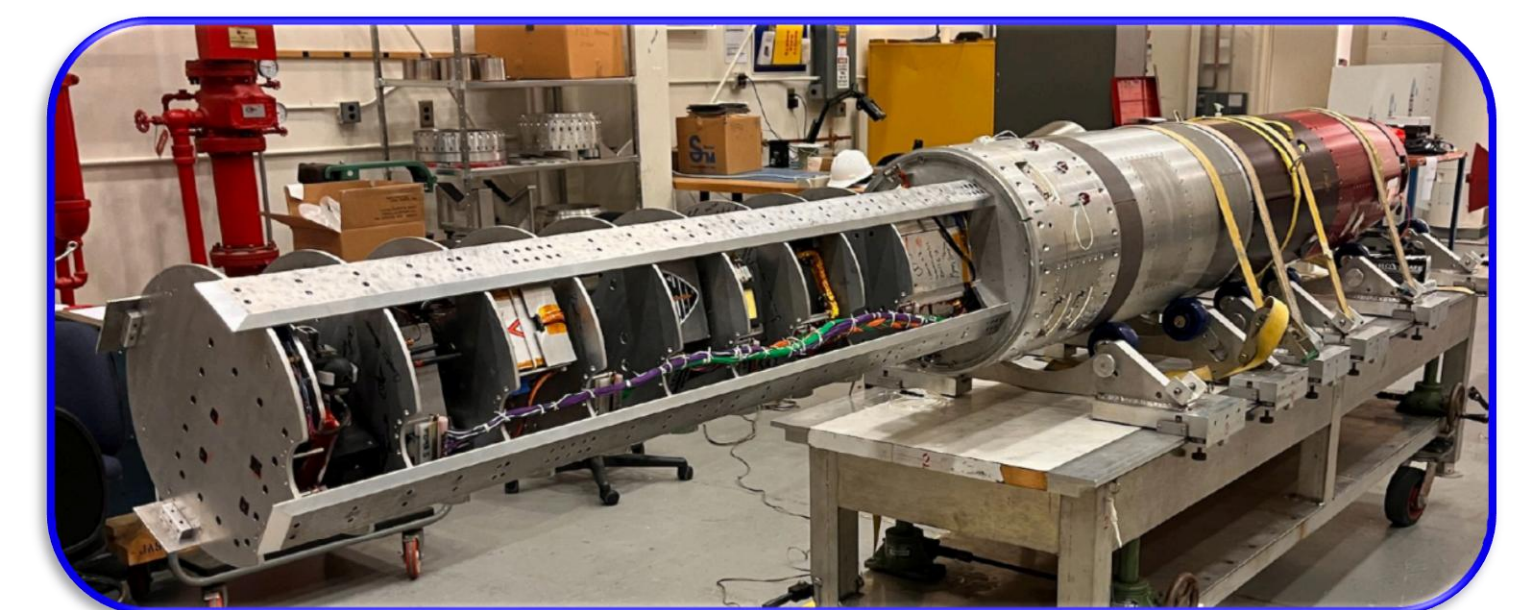

## EXPECTED OUTCOMES AND FUTURE PLANS:

Successful flight results will advance the LunaSat v8 to TRL 7, the HDM to TRL 5, and the SCOUT debris tracking system to TRL 5, directly supporting readiness for a future GLEE lunar mission. Mission data will inform next-generation HDM and LunaSat hardware design, while SCOUT results will establish a baseline for computer vision debris detection in microgravity. The PULSAR project also provides undergraduate researchers with direct experience in spacecraft design, testing, flight operations, and life cycle within a NASA-supported program.

