

ASEN 4013: Foundations of Propulsion

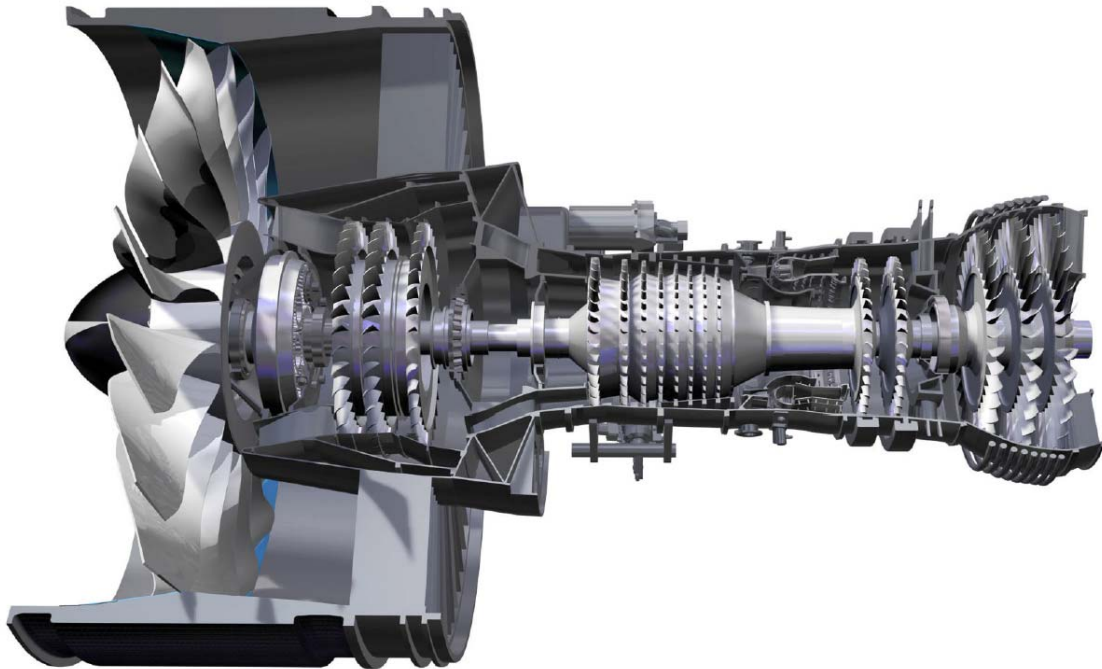

CLASSROOM: Benson Earth Sciences (BESC) 180
TuTh, 11:00am - 12:15pm

INSTRUCTOR: Prof. James Nabity
Office: ECAE 105
Phone: 303-492-3243
Email: james.nabity@colorado.edu
Office Hours: TuW, 1:00 – 2:00pm

Term Exams:
See the Schedule

Final Exam: TBD

ASSISTANTS:

TA: Mitch Woolever
Mitchell.Woolever@colorado.edu
Office Hours: Undergrad Lounge – M 1:00pm - 3:00pm, F 11:00am - 12:00pm
(Other locations such as the Seebass or BioServe Conference Rooms)

CA: Nick Dawson
nickdawson95@gmail.com

WEB SITE: <https://learn.colorado.edu/>

TEXTBOOK:

Required: Mattingly and Boyer (2016). **Elements of Propulsion Gas Turbines and Rockets, 2nd Ed.**, ISBN-13: 978-1-62410-371-1 (including supplementary material available by download)

Other Useful References:

1. Textbooks
 - a. Mattingly, J. D. (2006). Elements of Propulsion: Gas Turbines and Rockets, AIAA (Predecessor to the current text)
 - b. Oates, Aerothermodynamics of Gas Turbine and Rocket Propulsion, AIAA (A somewhat dated book on propulsion)
 - c. Hill P., and C. Peterson (1992). Mechanics and Thermodynamics of Propulsion, 2nd Ed., Addison--Wesley (an excellent, albeit dated, reference on the subject)
 - d. Sutton, G. P. and O. Biblarz (2001). Rocket Propulsion Elements, 8th Ed., Wiley (Classic text on rocket propulsion, extensively updated --- an excellent reference on the subject)
2. Journal and conference papers
3. Technical reports
4. Personal notes

PREREQUISITES: ASEN 3113 & APPM 2360

REQUIRED EQUIPMENT: Clickers

COURSE OBJECTIVES: The goal of this course is to build an understanding of the different types of propulsion systems (both airbreathing and rocket), their relative performance trade-offs, and how they fit within the context of a vehicle “system”. Specific emphasis will be placed on fundamental cycle analyses, component level understanding, and aspects of propulsion integration. Included are aspects of aerodynamics, thermodynamics, structural/thermal systems, and chemistry.

TOPICAL OUTLINE:

1. Introduction & Overview (Chapter 1)
2. Fundamentals (Chapters 2 & 3)
 - a. Engineering solution method
 - b. Thermodynamics
 - c. Control volume analysis
 - d. Perfect gas
 - e. Chemical reactions
 - f. Inviscid & compressible flows
 - g. Normal shock
3. Engine components (Chapters 3 & 11)
 - a. Simple flows
 - b. Inlets, nozzles and combustors
4. Analysis and performance of airbreathing propulsion systems (Chapters 4-8)
 - a. Aircraft gas turbine engine
 - b. Parametric cycle analysis of idealized engines
 - c. Component performance
 - d. Parametric cycle analysis of real engines
 - e. Engine performance analysis

5. Rocket Propulsion (Chapter 10)
6. Other Relevant Topics of Interest

COURSE ASSIGNMENTS:

- Reading
- Quizzes
- Homework
- Term Exams
- Final Exam

ACADEMIC INTEGRITY AND GRADE SCHEDULE:

Evaluated Outcomes: The Department of Aerospace Engineering Sciences has adopted a policy of assigning grades according to “evaluated outcomes” in each course:

- O1 Professional context and expectations (ethics, economics, business environment, etc.)
- O2 Current and historical perspective
- O3 Multidisciplinary, systems perspective
- O4 Written, oral, graphical communication ability
- O5 Knowledge of key scientific/engineering concepts
- O6 Ability to define and conduct experiments, use instrumentation
- O7 Ability to learn independently, find information
- O8 Ability to work in teams
- O9 Ability to design
- O10 Ability to formulate and solve problems
- O11 Ability to use and program computers

Evaluation of these outcomes allows an assessment of your performance and provides a major portion of the process we (the Faculty) use for continuous assessment and improvement of the entire AES curriculum. The model for these outcomes derives from several sources including the “Desired Attributes of an Engineer” as defined by The Boeing Company, and “curriculum reviews” from major aerospace corporations including The Boeing Co., Lockheed Martin Corp., and Ball Aerospace Corp. These inputs were combined with the AES faculty vision of the desired attributes of an aerospace engineer and the requirements of the Accreditation Board for Engineering and Technology (ABET) to produce this list of evaluated outcomes. Each assignment designed and graded to assess some combination of several or a few of the outcomes.

Grade Breakdown: Your final grade is determined according to the following percentage breakdown (see below for additional information regarding assignments and individual grade assessment).

Table 1. Grade Breakdown

Type	Description	Percentage
Individual	Quizzes	10%
	Term Exams	50% (25% each)
	Final Exam	30%
Group	Homework*	10%
Total		100%

* Although homework must be submitted individually, it can be discussed and therefore, counts as a ‘group’ grade.

Table 2. Letter Grade Assignment for Final Student Grading

Letter Grade	Percent Grade	4.0 Scale
A	93-100	4.0
A-	90-92	3.7
B+	87-89	3.3
B	83-86	3.0
B-	80-82	2.7
C+	77-79	2.3
C	73-76	2.0
C-	70-72	1.7
D	60-69	1.0
F	Below 60	0.0

IMPORTANT NOTES AND CLASS POLICIES:

- Homework assignments are due at the start of class on the due date and quizzes may be given at any point during a class, so be sure to attend regularly and arrive on time! If you must miss class for an excused absence, you may submit your homework early. **Late homework submittals are not accepted** - this includes homework slipped under the professor's door after class has started. However, if you will not be attending class, you may submit your homework prior to class by slipping it under the instructor's door.
- In the case of homework, laboratory report, presentation, or exam conflicts, you must make arrangements with the professor at least two weeks in advance. There are no unexcused make-up assignments or exams.**
- Each homework assignment will include a set of several problems, which you are expected to completely solve using the Engineering Problem Solving Approach. Your assignment will be partially graded for completeness (10pts), while two randomly selected problems will be graded in detail for accuracy (10pts each, 20pts total). Thus the final score for each homework set will be out of a total of 30pts and computed based upon the numeric breakdown below:

$$HW\ Score = P1\ score + P2\ score + 10pts \cdot \frac{\# \text{ remaining problems completed}}{\# \text{ remaining problems in the HW set}}$$

Solutions will be provided to you for all the problems when the graded homework sets are returned.

- Collaboration is permitted on homework. You may discuss the means and methods for formulating and solving problems and even compare answers, but you are not free to copy someone's assignment. Copying material from any resource (including solutions manuals) and submitting it as one's own is considered plagiarism and is an Honor Code violation. Remember, the less you think about the problems yourself, the less you actually learn, and the more difficult it will be to succeed on exams. **Every student is expected to turn in their own individual assignment for grading!**

- Group collaboration is permitted on homework, but efforts are individual. This means you may discuss the means and methods for solving problems and even compare answers, but you are not free to copy someone's work or the solutions manual. **The homework you submit must be your own. Copying material from any resource (including solutions manuals) and submitting it as one's own work is considered plagiarism and is an Honor Code violation. Keep in mind that the more you think about the problems yourself, the more you will learn, and the easier it will be to succeed on exams.**

Homework solutions must demonstrate an understanding of the principles involved by including diagrams, using correct notation and terminology, explaining the approach, showing the key steps to obtaining the solution, and outlining the answer with proper units. These problem-solving steps are critical for developing problem formulation skills.

- Collaboration on quizzes or exams, using another student's work as your own, or allowing another student to use your work as their own, is considered academic misconduct and will not be tolerated. If you are caught in any of these activities, you may receive a grade of "F" for the course and a report may be made to the Dean's office for further punitive action.**
- All homework must be submitted on 8.5×11-inch paper.** You may use both sides of ruled notebook paper. However, use only the front side of engineering paper. **Do not submit assignments on spiral notebook paper with ripped edges.** Multiple pages must be stapled in the upper-left corner, no paperclips or dog-ears. Your name (last, first), assignment number, and due date should be visible on the outside in the upper portion of each page, to the right of the fold. Written work must be neat and readable with adequate spacing and margins. You are responsible for legibility – no reevaluation will be granted. Unacceptably messy work will be returned to you ungraded and a score of zero recorded. Messy work will be docked points. **Final answers must be indicated with an arrow or box, or underlined.** Multiple answers (when only one is required) will be counted as incorrect.

Always submit work with a professional appearance. Neatness, clarity, and completeness count in the work world!

- Always have a calculator and your textbook for lecture and office hours.
- Use of MATLAB is permitted, but not always desirable. MATLAB code will not suffice for homework solutions, please write out your work in "human" readable format (we will not try to decipher your code). MATLAB figures should be legible, and have meaningful axes and legends.
- Attendance at all lectures is an important part of your training as an engineer and is expected. Some of the material covered in class is not in the textbook. Quizzes may be given during any lecture. **Like the exams, there are no unexcused make-ups for missed quizzes.**

A cordial atmosphere is expected at all times within the classroom. Respect and be courteous to other students. Maintain a quiet work atmosphere; excessive noise distracts others.

- If you forget to bring you Clicker to class (or your battery dies), a score of zero will be assigned for the quiz.
- Expect new material to be presented in both the lecture/discussion and laboratory periods. **Quizzes and exams can cover all material in the course including textbook, lecture/discussions, homework, and supplemental handouts.**

10. Rationale for course assignments:

- Reading assignments are to be completed *before* the lecture/discussion since this material will be on the quizzes. The lecture/discussions should help to clarify and supplement what you have read.
- Homework reinforces the mental processes that help you to become proficient in a subject. In addition to the assigned homework, we encourage you to work additional problems for practice. Before beginning any homework assignment, you should read the text and work the examples in the text.
- Exams and quizzes provide a gauge to determine what *you* have learned independently.
- Projects help you to learn how to synthesize the basic concepts, methods, and tools presented in the course curriculum.

GRADING PHILOSOPHY:

Assignments are graded to an absolute standard designed to indicate your level of competency in the course material. Minor adjustments may be made in the assignment of final grades, but there is a limited amount of “curving” in the course. The final grade indicates your readiness to continue to the next level in the curriculum. The AES faculty have set these standards based on our education, experience, interactions with industry, government laboratories, others in academe, and according to the criteria established by the ABET accreditation board.

The course grade is primarily dependent on individual measures of competency, i.e. exams and quizzes. The other course assignments are designed to enrich the learning experience and to enhance individual performance, not to substitute for sub-standard individual competency. Accordingly, group assignment grades are only incorporated into the final grade when the individual grade is a C or better. **In other words, if your individual average is below a C, the group-based grade fraction will not be averaged in to your final grade, which will then be based solely on your individual score.** This policy makes it important to use the group assignments to enhance your own learning. If the work in the assignment is split up among group members, be sure that the learning is not also split up, but is shared among the whole group. For these purposes, exams and quizzes are considered ‘individual’ grades (90%) while homework (10%) is considered a ‘group’ grade.

ACCOMMODATIONS:

Accommodation for Disabilities:

If you qualify for accommodations because of a disability, please submit your accommodation letter from Disability Services to your faculty member in a timely manner so that your needs can be addressed. Disability Services determines accommodations based on documented disabilities in the academic environment. Information on requesting accommodations is located on the [Disability Services website](http://www.colorado.edu/disabilityservices/students) (www.colorado.edu/disabilityservices/students). Contact Disability Services at 303-492-8671 or dsinfo@colorado.edu for further assistance. If you have a temporary medical condition or injury, see [Temporary Medical Conditions](#) under the Students tab on the Disability Services website and discuss your needs with your professor.

Observance of Religious Holidays and Absences from Classes and/or Exams:

Campus policy regarding religious observances requires that faculty make every effort to deal reasonably and fairly with all students who, because of religious obligations, have conflicts with scheduled exams, assignments or required attendance. In this class, the due dates for completion of assignments and the take home exam will be scheduled to avoid conflict with the observance of religious holidays. Please notify your professor should a conflict or need arise due to religious observance obligations.

See the [campus policy regarding religious observances](#) for full details.

Classroom Behavior:

Students and faculty each have responsibility for maintaining an appropriate learning environment. Those who fail to adhere to such behavioral standards may be subject to discipline. Professional courtesy and sensitivity are especially important with respect to individuals and topics dealing with race, color, national origin, sex, pregnancy, age, disability, creed, religion, sexual orientation, gender identity, gender expression, veteran status, political affiliation or political philosophy. Class rosters are provided to the instructor with the student's legal name. I will gladly honor your request to address you by an alternate name or gender pronoun. Please advise me of this preference early in the semester so that I may make appropriate changes to my records. For more information, see the policies on [classroom behavior](#) and the [Student Code of Conduct](#).

Sexual Misconduct, Discrimination, Harassment and/or Related Retaliation:

The University of Colorado Boulder (CU Boulder) is committed to maintaining a positive learning, working, and living environment. CU Boulder will not tolerate acts of sexual misconduct, discrimination, harassment or related retaliation against or by any employee or student. CU's Sexual Misconduct Policy prohibits sexual assault, sexual exploitation, sexual harassment, intimate partner abuse (dating or domestic violence), stalking or related retaliation. CU Boulder's Discrimination and Harassment Policy prohibits discrimination, harassment or related retaliation based on race, color, national origin, sex, pregnancy, age, disability, creed, religion, sexual orientation, gender identity, gender expression, veteran status, political affiliation or political philosophy. Individuals who believe they have been subject to misconduct under either policy should contact the Office of Institutional Equity and Compliance (OIEC) at 303-492-2127. Information about the OIEC, the above referenced policies, and the campus resources available to assist individuals regarding sexual misconduct, discrimination, harassment or related retaliation can be found at the [OIEC website](#).

Honor Code:

All students enrolled in a University of Colorado Boulder course are responsible for knowing and adhering to [the academic integrity policy](#). Violations of the policy may include: plagiarism, cheating, fabrication, lying, bribery, threat, unauthorized access to academic materials, clicker fraud, resubmission, and aiding academic dishonesty. All incidents of academic misconduct will be reported to the Honor Code Council (honor@colorado.edu; 303-735-2273). Students who are found responsible for violating the academic integrity policy will be subject to nonacademic sanctions from the Honor Code Council as well as academic sanctions from the faculty member. Additional information regarding the academic integrity policy can be found at the [Honor Code Office website](#).