

**Physics 3330 Final Exam, Dec 1999**

1) I wish to measure a very low resistance (of the order of an ohm) accurately. What should I do and why?

2) Assume that  $R_1 = 3 \cdot R_2$  and that the input signal is a sine from  $-10\text{V}$  to  $+10\text{V}$ . Assume the output saturation voltage is  $\pm 12\text{V}$ .

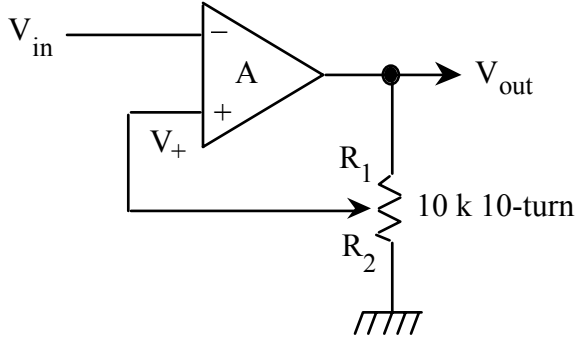

Draw the output waveform superimposed on the input waveform.

3) A square wave is input to a circuit, and the output is the rounded function as shown. Design two circuits to perform this function – one using a capacitor and one using an inductor. Let  $R = 1\text{k}\Omega$ .

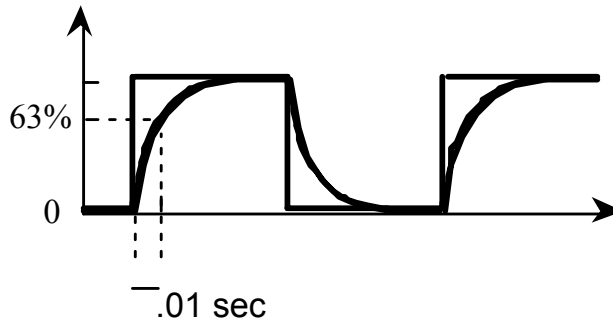

4) Write an equation for  $V_{out}$  in terms of  $V_1$ ,  $V_2$ , and any necessary  $R$ 's.

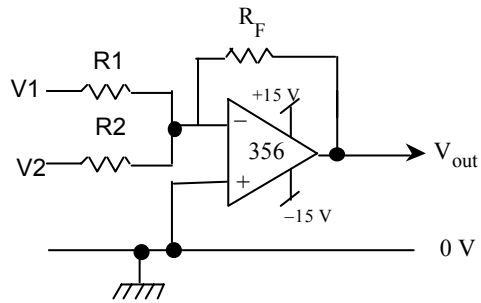

5) Design an op-amp based current-voltage amplifier with gain  $25\text{ V/mA}$ .

- 6) An op-amp with unity gain frequency of 5 MHz is connected in a feedback circuit as shown at the right. The open loop DC gain of the op-amp is  $10^5$ . What is the closed loop gain at 50 KHz?

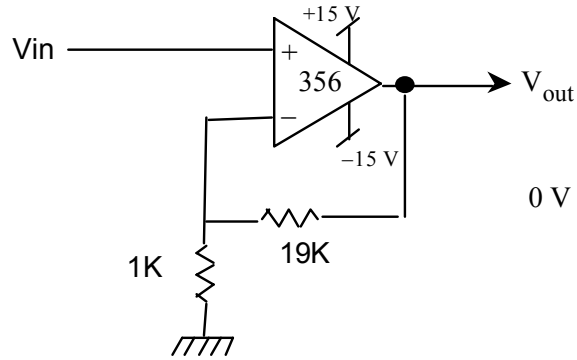

- 7) Roughly draw the V vs. I curve for a diode. Make sure you label the axes and show the 0.6 V drop for a silicon diode.
- 8) The transistor circuit drawn below has  $R_1=20k$ ,  $R_2=5k$ ,  $R_C=1.5K$ ,  $R_E=0.4k$ . Figure out the DC or quiescent voltages and the small signal voltage gain. Do not ignore the effect of the intrinsic emitter resistance  $R_e$ .

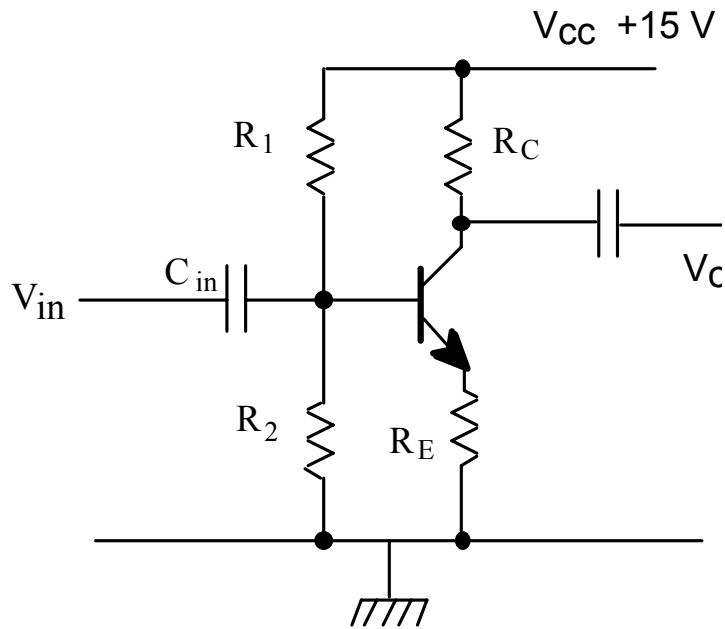

- 9) Implement the OR operation ( $A + B$ ) using only NAND gates.
- 10) Using NOR gates, show how AND, OR, and NAND can be made.
- 11) Reduce the following Boolean expressions to their simplest forms

- a)  $ABCD + \overline{A}BCD$   
 b)  $AB + \overline{AC} + \overline{ABC}(AB+C)$   
 c)  $A(\overline{AB}+B)$

12) I wish to make a mod-100 ripple-through counter using JK flip flops. How many flip flops do I need to use?

13) What is the advantage of a synchronous counter compared to a ripple-through counter?

14) What were the best and worst parts about the class? Please give constructive criticism about how it can be improved in the future.