

Interdisciplinary Telecommunications Program  
University of Colorado &  
Hagler Bailly

Copyright © 1997, 1998; James Alleman. All Rights Reserved.

## Agenda

---

- **Public Policy Overview**
- **Role of Competition**
- **Competitive Overview**
- **Mergers/Acquisitions**
- **Price Discrimination**
- **Cross-subsidies**
- **Conclusion**

James Alleman

University of Colorado & Hagler Bailly

## Public Policy Overview

---

- **Goals**
- **Instruments**
- **Obstacles**

James Alleman

University of Colorado & Hagler Bailly

## Public Policy Overview

---

- **Cost Minimization**
- **"Correct" Prices**
- **Rent Extraction (Monopoly)**
- **Equity?**

James Alleman

University of Colorado & Hagler Bailly

## Public Policy Overview

---

- **"...unleashing monopolies before real competition could mean..."**
  - ▶ **Higher prices for consumers**
  - ▶ **Hinder competition**

James Alleman

University of Colorado & Hagler Bailly

## Public Policy Overview

---

- **"...unleashing monopolies before real competition could mean..."**
  - ▶ **Higher prices for consumers**
  - ▶ **Hinder competition**
- **Transitional safeguards needed**

James Alleman

University of Colorado & Hagler Bailly

## Public Policy Overview

---

- "...unleashing monopolies before real competition could mean..."
- Transitional safeguards needed
- RBOC's 14 points

James Alleman

University of Colorado & Hagler Bailly

## Public Policy: Instruments

---

- Regulation/Social Control
  - ▶ ~~Rate of Return Regulation (ROR)~~
  - ▶ Benchmark (Yardstick)
  - ▶ Incentive Regulation
  - ▶ No Regulation
- Antitrust / Monopoly Policy

James Alleman

University of Colorado & Hagler Bailly

## Incentive/Price Caps Regulation

---

- Competitive Entry Encouraged
- Limit on the Incumbent's Prices
- Productivity Factor

James Alleman

University of Colorado & Hagler Bailly

## Role of Competition

---

- Allocation of Resources
- Incentive for Efficiency
- Threat of Entry Discipline

James Alleman

University of Colorado & Hagler Bailly

## Role of Competition

---

- Incentive for Efficiency
  - ▶ Prices => costs
  - ▶ Pressure to reduce costs
  - ▶ Selection of more efficient firms
  - ▶ Promote innovation
  - ▶ Diminish regulatory imperfections

James Alleman

University of Colorado & Hagler Bailly

## Additional Motivation for Competition

---

- Product Differentiation
- Cost Differences
- Benchmark Competition (Yardstick)

James Alleman

University of Colorado & Hagler Bailly

## Competitive Policy Overview

---

- **Institutional Advantage** (Incumbent)
- **Technology Advantage** (Incumbent)
- **Regulatory/Competitive Synergy**

Nuttall, Robin and John Vickers, *Competition Policy for Regulated Utility Industry in Britain*, Applied Economics Discussion Papers, Institute of Economics and Statistics, Oxford No. 178, February, 1996.

James Alleman

University of Colorado & Hagler Bailly

## Competitive Policy Overview

---

- **Institutional Advantage** (Incumbent)
  - ▶ Institutionalized cross-subsidies
  - ▶ Name recognition
  - ▶ Established customer-base

James Alleman

University of Colorado & Hagler Bailly

## Competitive Policy Overview

---

- **Institutional Advantage**
- **Technology Advantage** (Incumbent)
  - ▶ Numbering
  - ▶ Metering?
  - ▶ High customer switching costs

James Alleman

University of Colorado & Hagler Bailly

## Competitive Policy Assessment

---

- **Competitive Entry**
- **Merger/Acquisition Policy**
- **Price Discrimination**
- **Cross-Subsidies**
- **Universal Service Obligations**

James Alleman

University of Colorado & Hagler Bailly

## Competitive Policy Overview

---

- ...
- **Competitive/Regulatory Synergy**
  - ▶ Substitutes for regulation
  - ▶ Complements regulation
  - ▶ Regulation can distort competition

James Alleman

University of Colorado & Hagler Bailly

## Mergers/Acquisitions/Joint Ventures

---

- **Principles**
- **Policy**
- **Recommendations**

James Alleman

University of Colorado & Hagler Bailly

## Merger Policy Impact

---

- **Horizontal Mergers Allowed**

James Alleman

University of Colorado & Hagler Bailly

## Horizontal Mergers Allowed

---

- **Eliminates Competition**
- **Removed Benchmark Competition**
- **Economies of Scale?**
- **Access Bottleneck Enhanced?**

James Alleman

University of Colorado & Hagler Bailly

## Vertical Mergers

---

- **Intermediate Price Problem**
- **Market Foreclosure**
- **Economies of Scope**

James Alleman

University of Colorado & Hagler Bailly

## Conglomerate Mergers

---

- **Economies of Scope**

James Alleman

University of Colorado & Hagler Bailly

## Price Discrimination

---

- **Principals**
- **Policy**
- **Recommendations**

James Alleman

University of Colorado & Hagler Bailly



Interdisciplinary Telecommunications Program  
University of Colorado &  
Hagler Bailly

Copyright © 1997, 1998; James Alleman. All Rights Reserved.

## Price Discrimination

---

- **Cost Justified**
- **Not Simply Uniform Price**
- **Not Pejorative**
- **Non-linear Prices**

James Alleman

University of Colorado & Hagler Bailly

## Price Discrimination

---

- **First-degree**
- **Second-degree**
- **Third-degree**

James Alleman

University of Colorado & Hagler Bailly

## Price Discrimination

---

- **First-degree (perfect)**
  - ▶ Captures total consumers' surplus
  - ▶ Pareto efficient / output
  - ▶ Cannot improve CS + PS
  - ▶ Demand curve is marginal revenue
  - ▶ Example
    - Generic
    - Doctor?

James Alleman

University of Colorado & Hagler Bailly

## Price Discrimination

---

- **First-degree**
- **Second-degree**
  - ▶ Group customers
    - College students/elderly
    - Business travelers/customers
  - ▶ Different prices for groups
  - ▶ Same discounts, all customers
  - ▶ Self-selecting

James Alleman

University of Colorado & Hagler Bailly

## Price Discrimination

---

- **First-degree**
- **Second-degree**
  - ▶ Group customers
  - ▶ Different prices for groups
  - ▶ Self-selecting
  - ▶ Example (graphic & airlines)  
(Varian, p.428)

James Alleman

University of Colorado & Hagler Bailly

## Price Discrimination

---

- **First-degree**
- **Second-degree (Non-linear Pricing)**
  - ▶ Group customers
  - ▶ Different prices for groups
  - ▶ Self-selecting
  - ▶ Example
  - ▶ Quality or quantity
  - ▶ May be Pareto improving

James Alleman

University of Colorado & Hagler Bailly

## Second-degree Price Discrimination

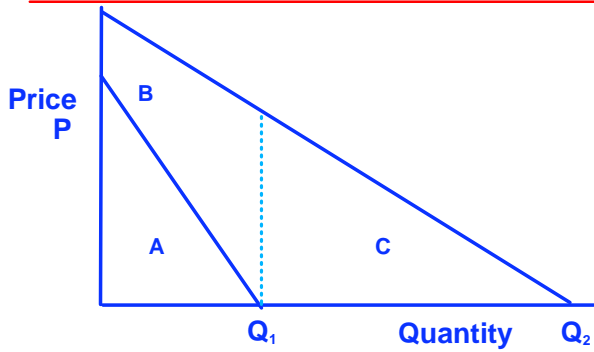

James Alleman

University of Colorado & Hagler Bailly

## Second-degree Price Discrimination

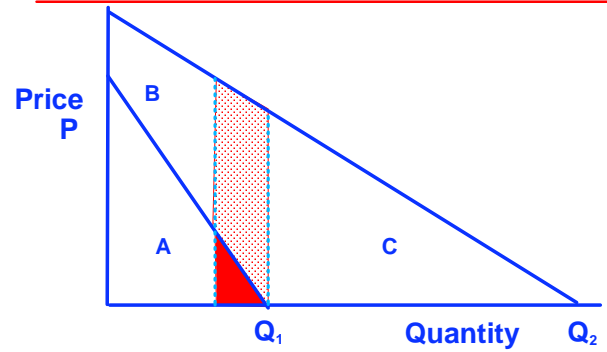

James Alleman

University of Colorado & Hagler Bailly

## Second-degree Price Discrimination

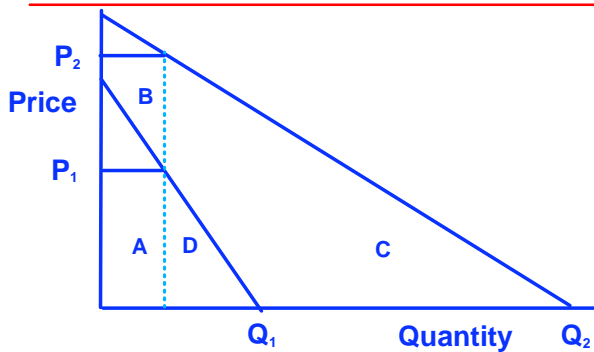

James Alleman

University of Colorado & Hagler Bailly

## Price Discrimination

- **Non-linear Pricing (Second-degree)**
  - ▶ **Volume (quantity) discounts**
  - ▶ **Declining block pricing**
  - ▶ **Bulk tariffs**
  - ▶ **Efficiency / welfare enhancing**

James Alleman

University of Colorado & Hagler Bailly

## Price Discrimination

- **Non-linear Pricing**
- **Efficiency Improved**
  - ▶ **Examples:**
  - ▶ **Mr. Bid and Little**
  - ▶ **Peak/Off-peak pricing**
  - ▶ **Self-selecting two-part tariffs**

James Alleman

University of Colorado & Hagler Bailly

## Price Discrimination

- **First-degree**
- **Second-degree**
- **Third-degree**
  - Different Prices,**
  - Different Customers Class**
    - ▶ **Business/Residential**
    - ▶ **Rural/Urban**

James Alleman

University of Colorado & Hagler Bailly

## Price Discrimination

---

- **First-degree**
- **Second-degree**
- **Third-degree**
  - ▶ **Different prices**
  - ▶ **Different customer classes**
  - ▶ **Example**

James Alleman

University of Colorado & Hagler Bailly

## Price Discrimination

---

- **First-degree**
- **Second-degree**
- **Third-degree**

James Alleman

University of Colorado & Hagler Bailly

## Price Discrimination

---

- **First-degree Discrimination**
- **Second-degree**
- **Third-degree**
  - ▶ **Not Uniform Prices**
  - ▶ **Non-linear Pricing**
  - ▶ **Efficiency/Profits Improved**
- **Predatory Pricing**

James Alleman

University of Colorado & Hagler Bailly

## Cross-Subsidies

---

- **No Market Test**
- **Inefficient**
- **Avoids Competition**
- **Anti-Competitive**

James Alleman

University of Colorado & Hagler Bailly

## Universal Service

---

- **Inefficient**
  - ▶ **Not Marginal Subscribers**
  - ▶ **Not Targeted**
  - ▶ **Not Desired**
- **Incidence Not Addressed**
- **Companies Subsidized**

James Alleman

University of Colorado & Hagler Bailly

## Incidence

---

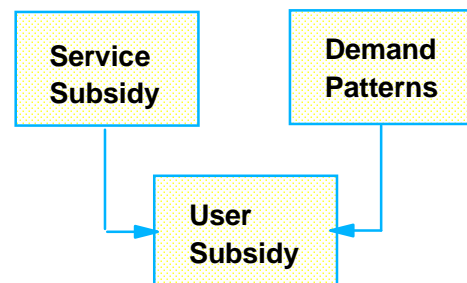

James Alleman

University of Colorado & Hagler Bailly

## Anti-competitive

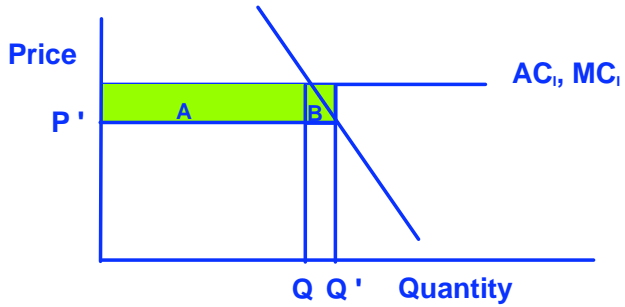

James Alleman

University of Colorado & Hagler Bailly

## Anti-competitive

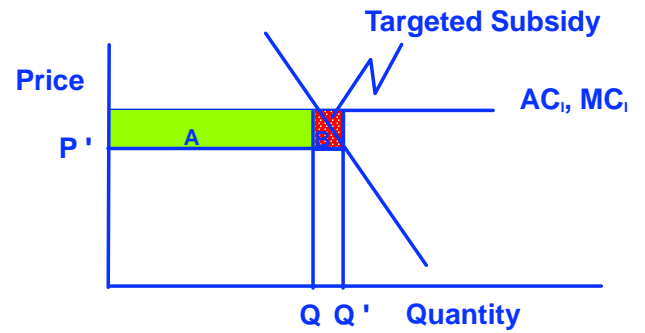

James Alleman

University of Colorado & Hagler Bailly

## Anti-competitive

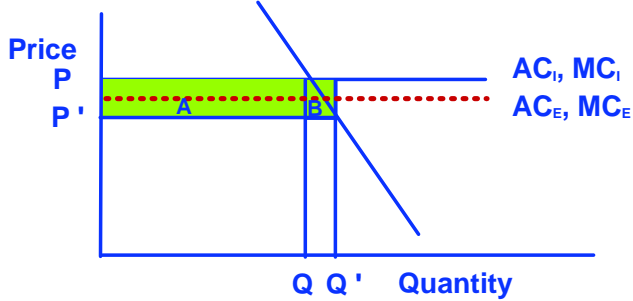

James Alleman

University of Colorado & Hagler Bailly

## Anti-competitive

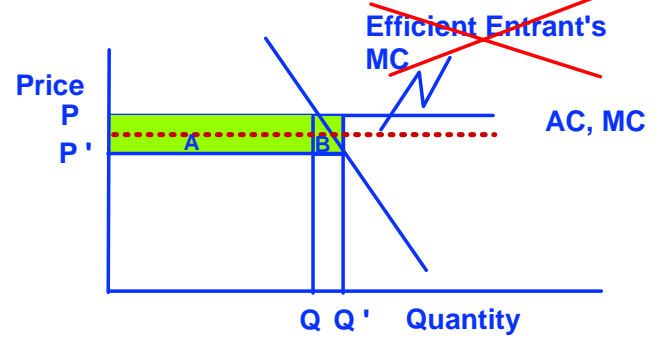

James Alleman

University of Colorado & Hagler Bailly

Efficient entrant excluded from the market!

## Agenda

- **Public Policy Overview**
- **Pre-Telecommunications Act**
- **Interconnection Pricing**
  - ▶ **Problem**
  - ▶ **Goals**
  - ▶ **Solution?**

James Alleman

University of Colorado & Hagler Bailly

## Intermediate Pricing

- **See separate presentation**

James Alleman

University of Colorado & Hagler Bailly