

CU-CAS-97-09

CENTER FOR AEROSPACE STRUCTURES

**THE CONSTRUCTION OF FREE-FREE
FLEXIBILITY MATRICES AS
GENERALIZED STIFFNESS INVERSES**

by

C. A. Felippa, K. C. Park and M. R. Justino Filho

April 1997

**COLLEGE OF ENGINEERING
UNIVERSITY OF COLORADO
CAMPUS BOX 429
BOULDER, COLORADO 80309**

The Construction of Free-Free Flexibility Matrices as Generalized Stiffness Inverses

CARLOS A. FELIPPA, K. C. PARK AND M. R. JUSTINO FILHO

Department of Aerospace Engineering Sciences
and Center for Aerospace Structures
University of Colorado
Boulder, Colorado 80309-0429, USA

April 1997

Report No. CU-CAS-97-09

Research supported by the National Science Foundation under Grant ECS-9217394 and by Sandia National Laboratories under Contracts AS-5666 and AS-9991. Submitted for publication to *Computer & Structures*. (It appeared in Vol. 88, (1998), pp. 411–418, of that journal)

The Construction of Free-Free Flexibility Matrices as Generalized Stiffness Inverses

C. A. Felippa, K. C. Park and M. R. Justino Filho

*Department of Aerospace Engineering Sciences
and Center for Aerospace Structures
University of Colorado
Boulder, Colorado 80309-0429, USA*

Keywords: finite element method, flexibility matrix, stiffness matrix, generalized inverse, projector, direct flexibility method

Abstract — We present generalizations of the classical structural flexibility matrix. Direct or indirect computation of flexibilities as “influence coefficients” has traditionally required pre-removal of rigid body modes by imposing appropriate support conditions. Here the flexibility of an individual element or substructure is directly obtained as a particular generalized inverse of the free-free stiffness matrix. This entity is called a free-free flexibility matrix. It preserves exactly the rigid body modes. The definition is element independent. It only involves access to the stiffness generated by a standard finite element program as well as a separate geometric construction of the rigid body modes. With this information, the computation of the free-free flexibility can be done by solving linear equations and does not require the solution of an eigenvalue problem or performing a singular value decomposition. Flexibility expressions for symmetric and unsymmetric free-free stiffnesses are studied. For the unsymmetric case two flexibilities, one preserving the Penrose conditions and the other the spectral properties, are examined. The two versions coalesce for symmetric matrices.

1. MOTIVATION

The direct or indirect computation of structural flexibilities as “influence coefficients” has traditionally required precluding rigid body modes by imposing appropriate support conditions. This approach agrees with conventional experimental practices for static tests, in which forces are applied to a supported structure and deflections measured.

There are applications, however, for which it is convenient to have an expression for the flexibility of a free-free finite element or assembly of elements. The qualifier “free-free” is used here to denote that *all* rigid body motions are unrestrained. This entity will be called a *free-free flexibility* matrix, and denoted by \mathbf{F} .

In the symmetric case, the free-free flexibility represents the dual of the well known free-free stiffness matrix \mathbf{K} , in the sense that \mathbf{F} and \mathbf{K} are the pseudo-inverses (that is, the Moore-Penrose generalized inverses) of each other. The general expression for the pseudo-inverse of a singular symmetric matrix such as \mathbf{K} involves its singular value decomposition (SVD) or, equivalently, knowledge of the eigensystem of \mathbf{K} ; see e.g. Stewart and Sun [1]. These kind of analysis is not only expensive, but notoriously sensitive to rank decisions when carried out in inexact arithmetic. That is: when can a small singular value be replaced by zero? Such decisions depend on the problem as well as the working computer precision. Another disadvantage of going through an explicit spectral analysis is that symbolic work is seriously impaired because analytical expressions for eigenvalues are not available unless \mathbf{K} has very low order.

Explicit expressions are presented here that relate \mathbf{K} and \mathbf{F} but involve only matrix inversions or, equivalently, the solution of linear systems. These expressions assume the availability of a basis matrix \mathbf{R} for the rigid body modes. Often this matrix may be constructed by geometric arguments *separately* from \mathbf{K} and \mathbf{F} . The formulas are well suited for symbolic manipulation in the case of simple individual elements.

2. PRELIMINARIES

2.1 Substructures

A substructure is defined here as an assembly of finite elements that does not possess zero-energy modes (also called spurious modes or kinematic deficiencies) aside from rigid body modes (RBM). It includes individual elements and a complete structure as special cases. The total number of nodal degrees of freedom of the substructure is called N_f .

Should it be necessary, substructures are identified by a superscript enclosed in brackets, for example $\mathbf{K}^{[3]}$ is the stiffness of substructure 3. Because the following exposition deals only with individual substructures, the identifying superscript will be omitted to reduce clutter.

Figure 1(a) depicts a two-dimensional substructure, and the force systems acting on its nodes from external agents. The applied forces \mathbf{f} are given as data. The interaction forces $\boldsymbol{\lambda}$ are exerted by other connected substructures. If the substructure is supported or partly supported, it is rendered *free-free* on replacing the supports by reaction forces \mathbf{s} as shown in Figure 1(b). The total force vector acting on the substructure is the superposition

$$\mathbf{f}_a = \mathbf{f} + \boldsymbol{\lambda} + \mathbf{s} \quad (1)$$

where each vector has length N_f . Vectors $\boldsymbol{\lambda}$ and \mathbf{s} are completed with zero entries as appropriate for conformity.

At each node n considered as a free body, the internal force is defined to be the resultant of the acting forces, as depicted in Figure 1(c). Hence

$$\mathbf{p} = \mathbf{f}_a, \quad \text{or} \quad \mathbf{f} + \boldsymbol{\lambda} + \mathbf{s} - \mathbf{p} = \mathbf{0}, \quad (2)$$

is the statement of node by node equilibrium.

For some applications it is natural to view support reactions as interaction forces by viewing the “ground” as another substructure. In such cases vector \mathbf{s} is merged with $\boldsymbol{\lambda}$.

2.2 Rigid Body Modes and Self Equilibrium

As for the kinematics, the free-free substructure has $N_r > 0$, linearly independent rigid body modes or RBMs. Rigid motions are characterized through the RBM-basis matrix \mathbf{R} , dimensioned $N_f \times N_r$, such that any rigid node displacement can be represented as $\mathbf{u}_r = \mathbf{R}\mathbf{a}$ where \mathbf{a} is a vector of N_r modal amplitudes. The total displacement vector \mathbf{u} can be written as the superposition of deformational and rigid motions:

$$\mathbf{u} = \mathbf{d} + \mathbf{u}_r = \mathbf{d} + \mathbf{R}\mathbf{a}, \quad (3)$$

Matrix \mathbf{R} may be constructed by taking as columns N_r linearly independent rigid displacement fields evaluated at the nodes. For convenience those columns are assumed to be *orthonormalized* so that $\mathbf{R}^T\mathbf{R} = \mathbf{I}$, the identity matrix of order N_r . The orthogonal projector associated with \mathbf{R} is the symmetric matrix

$$\mathbf{P} = \mathbf{I} - \mathbf{R}(\mathbf{R}^T\mathbf{R})^{-1}\mathbf{R}^T = \mathbf{I} - \mathbf{R}\mathbf{R}^T. \quad (4)$$

where \mathbf{I} is the $N_f \times N_f$ identity matrix. [The last simplification in (4) arises from the assumed orthonormality of \mathbf{R} .] Note that $\mathbf{P}^2 = \mathbf{P}$ and $\mathbf{P}\mathbf{R} = \mathbf{R}^T\mathbf{P} = \mathbf{0}$.

Application of the projector (4) to \mathbf{u} extracts the deformational node displacements $\mathbf{d} = \mathbf{P}\mathbf{u}$. Subtracting these from the total displacements yields the rigid motions $\mathbf{u}_r = \mathbf{u} - \mathbf{d} = (\mathbf{I} - \mathbf{P})\mathbf{u} = \mathbf{R}\mathbf{R}^T\mathbf{u}$. Using the idempotent property $\mathbf{P}^2 = \mathbf{P}$ it is easy to verify that $\mathbf{d}^T\mathbf{u}_r = 0$.

Invoking the Principle of Virtual Work for the substructure under virtual rigid motions $\mathbf{R}\delta\mathbf{a}$ yields

$$\mathbf{R}^T\mathbf{p} = \mathbf{R}^T(\mathbf{f} + \boldsymbol{\lambda} + \mathbf{s}) = \mathbf{0}, \quad (5)$$

as the statement of overall self-equilibrium for the substructure.

2.3 Generalized Inverse Terminology

We summarize here the definition of two types of generalized inverses that appear in the sequel, and introduce related terminology. For a complete coverage of the subject the book by Rao and Mitra [2] may be consulted.

Consider a square real matrix \mathbf{A} , which may be unsymmetric and singular but is assumed non-defective (that is, it has a complete eigensystem). Its *pseudo-inverse*, also called the Moore-Penrose generalized inverse, is the matrix \mathbf{X} that satisfies the four Penrose conditions

$$\mathbf{A}\mathbf{X}\mathbf{A} = \mathbf{A}, \quad \mathbf{X}\mathbf{A}\mathbf{X} = \mathbf{X}, \quad \mathbf{A}\mathbf{X} = (\mathbf{A}\mathbf{X})^T, \quad \mathbf{X}\mathbf{A} = (\mathbf{X}\mathbf{A})^T, \quad (6)$$

The pseudo-inverse is identified as $\mathbf{X} = \mathbf{A}^+$ in the sequel. It can be shown that this matrix exists and is unique [1].

The spectral generalized inverse of \mathbf{A} or simply *sg-inverse*, is the matrix \mathbf{A}^\dagger that has the same eigenvectors as \mathbf{A} , and whose nonzero eigenvalues are the reciprocals of the corresponding nonzero eigenvalues of \mathbf{A} . (The name and notations for this class of g-inverses is not standardized in the literature.) More precisely, if the nonzero eigenvalues of \mathbf{A} are λ_i and associated left and right bi-orthonormalized eigenvectors are \mathbf{x}_i and \mathbf{y}_i , respectively, we have

$$\mathbf{A} = \sum_i \lambda_i \mathbf{x}_i \mathbf{y}_i^T, \quad \mathbf{A}^\dagger = \sum_i \frac{1}{\lambda_i} \mathbf{x}_i \mathbf{y}_i^T, \quad \lambda_i \neq 0, \quad \mathbf{x}_i^T \mathbf{y}_j = \delta_{ij}. \quad (7)$$

where δ_{ij} is the Kronecker delta. If \mathbf{A} is symmetric, $\mathbf{A}^+ = \mathbf{A}^\dagger$, but for unsymmetric matrices these two g-inverses generally differ. It can be shown [2] that \mathbf{A}^\dagger always satisfies the first two Penrose conditions (6) but not necessarily the others. Note, however, that \mathbf{A} , \mathbf{A}^+ and \mathbf{A}^\dagger have the same rank.

3. SYMMETRIC STIFFNESS AND FLEXIBILITY MATRICES

3.1 Definitions

We begin with the symmetric case, which is the most important one in practice. The well known free-free stiffness matrix \mathbf{K} of a linearly elastic substructure relates node displacements to node forces through the stiffness equations:

$$\mathbf{K}\mathbf{u} = \mathbf{p} = \mathbf{f} + \boldsymbol{\lambda} + \mathbf{s}, \quad \mathbf{K} = \mathbf{K}^T. \quad (8)$$

If \mathbf{K} models all rigid motions exactly, $\mathbf{R}^T \mathbf{K} = \mathbf{K} \mathbf{R}$ must vanish identically on account of (5). Such a stiffness matrix will be called *clean* as regards rigid body motions.

The free-free flexibility \mathbf{F} of the substructure is defined by the expressions

$$\mathbf{F} = \mathbf{P}(\mathbf{K} + \mathbf{R}\mathbf{R}^T)^{-1} = (\mathbf{K} + \mathbf{R}\mathbf{R}^T)^{-1} \mathbf{P} = \mathbf{F}^T. \quad (9)$$

The symmetry of \mathbf{F} follows from the spectral properties discussed below. Using \mathbf{F} we can write the free-free flexibility matrix equation dual to (8) as

$$\mathbf{F}\mathbf{p} = \mathbf{d} = \mathbf{P}\mathbf{u} = \mathbf{u} - \mathbf{u}_r. \quad (10)$$

Premultiplication by \mathbf{R}^T and use of (5) shows that $\mathbf{F}\mathbf{R} = \mathbf{0}$.

If the substructure is fixed (that is, fully restrained against all RBMs), matrix \mathbf{R} is void. The definition (9) then collapses to that of the ordinary structural flexibility $\mathbf{F} = \mathbf{K}^{-1}$ whereas (10) reduces to $\mathbf{F}\mathbf{p} = \mathbf{u}$. Because of coalescence in the fully-supported case, the same matrix symbol \mathbf{F} can be used without risk of confusion.

3.2 Spectral and Duality Properties

The basic properties can be expressed in spectral language as follows. The free-free stiffness \mathbf{K} has two kind of eigenvalues:

1. N_r zero eigenvalues pertaining to rigid motions. The associated eigenvector space is spanned by the columns of \mathbf{R} , because that basis matrix is assumed to be orthonormal.
2. $N_d = N_f - N_r$ nonzero eigenvalues λ_i . The associated orthonormalized “deformational eigenvectors” \mathbf{x}_i satisfy $\mathbf{K}\mathbf{x}_i = \lambda_i\mathbf{x}_i$, $\mathbf{R}^T\mathbf{x}_i = \mathbf{0}$ and $\mathbf{x}_i^T\mathbf{x}_j = \delta_{ij}$.

The eigenvectors of $\mathbf{K} + \mathbf{R}\mathbf{R}^T$ are identical to those of \mathbf{K} but the RBM eigenvalues are raised to unity, giving the spectral decompositions

$$\mathbf{K} + \mathbf{R}\mathbf{R}^T = \sum_{i=1}^{N_d} \lambda_i \mathbf{x}_i \mathbf{x}_i^T + \mathbf{R}\mathbf{R}^T, \quad (\mathbf{K} + \mathbf{R}\mathbf{R}^T)^{-1} = \sum_{i=1}^{N_d} \frac{1}{\lambda_i} \mathbf{x}_i \mathbf{x}_i^T + \mathbf{R}\mathbf{R}^T. \quad (11)$$

By construction the projector $\mathbf{P} = \mathbf{I} - \mathbf{R}\mathbf{R}^T$ has N_d unit eigenvalues whose invariant eigenspace is spanned by the \mathbf{x}_i , and the same null eigenspace as \mathbf{K} . Consequently, use of orthogonality properties yields the spectral decompositions

$$\mathbf{P} = \sum_{i=1}^{N_d} \mathbf{x}_i \mathbf{x}_i^T, \quad \mathbf{F} = \mathbf{P}(\mathbf{K} + \mathbf{R}\mathbf{R}^T)^{-1} = \sum_{i=1}^{N_d} \frac{1}{\lambda_i} \mathbf{x}_i \mathbf{x}_i^T. \quad (12)$$

The foregoing relations show that the three symmetric matrices \mathbf{K} , \mathbf{F} and \mathbf{P} have the same eigenvectors. Consequently they (and their powers) can be commuted at will. For example, $\mathbf{F}^\alpha \mathbf{K}^\beta \mathbf{P}^\gamma = \mathbf{K}^\beta \mathbf{P}^\gamma \mathbf{F}^\alpha$ for any scalar exponents (α, β, γ) .

Commutativity proves the symmetrization in (9). Other important relations that emanate from the spectral decompositions are

$$\mathbf{K} = \mathbf{P}(\mathbf{F} + \mathbf{R}\mathbf{R}^T)^{-1} = (\mathbf{F} + \mathbf{R}\mathbf{R}^T)^{-1}\mathbf{P} = \mathbf{K}^T, \quad (13)$$

$$(\mathbf{K} + \alpha\mathbf{R}\mathbf{R}^T)(\mathbf{F} + \beta\mathbf{R}\mathbf{R}^T) = \mathbf{I} + (\alpha\beta - 1)\mathbf{R}\mathbf{R}^T = \mathbf{P} + \alpha\beta\mathbf{R}\mathbf{R}^T \quad (\alpha, \beta \text{ arbitrary scalars}), \quad (14)$$

$$\mathbf{K}\mathbf{R} = \mathbf{F}\mathbf{R} = \mathbf{P}\mathbf{R} = \mathbf{0}, \quad (15)$$

$$\mathbf{K}\mathbf{F}\mathbf{K} = \mathbf{K}, \quad \mathbf{F}\mathbf{K}\mathbf{F} = \mathbf{F}, \quad (\mathbf{K}\mathbf{F})^T = \mathbf{F}\mathbf{K} = \mathbf{K}\mathbf{F} = \mathbf{P}, \quad (\mathbf{F}\mathbf{K})^T = \mathbf{K}\mathbf{F} = \mathbf{F}\mathbf{K} = \mathbf{P}. \quad (16)$$

This relation catalog shows that \mathbf{K} and \mathbf{F} are *dual*, because exchanging them leaves all formulas intact.

Comparing to the definitions (6) and (7) it is seen that \mathbf{F} and \mathbf{K} are both pseudo-inverses and sg-inverses of each other. The practical importance of the explicit relation (9) is that if \mathbf{K} and \mathbf{R} are known, \mathbf{F} can be *computed by solving linear equations* without need of the more expensive eigenvalue analysis of \mathbf{K} . This is especially important for substructures containing hundreds or thousands of elements, because linear equation solvers — with some clever rearrangements — can take advantage of the natural sparsity of \mathbf{K} . The stiffness matrix can be efficiently generated by the Direct Stiffness Method using existing finite element libraries, whereas the construction of \mathbf{R} from geometric arguments is straightforward as explained below.

3.3 Alternative Expressions

The flexibility expressions (9) are actually the first two of the following 12 formulas for \mathbf{F} :

$$\begin{aligned}
& \mathbf{P}(\mathbf{K} + \mathbf{R}\mathbf{R}^T)^{-1}, & (\mathbf{K} + \mathbf{R}\mathbf{R}^T)^{-1} \mathbf{P}, & \mathbf{P}(\mathbf{K} + \mathbf{R}\mathbf{R}^T)^{-1} \mathbf{P}, \\
& \mathbf{P}(\mathbf{P}\mathbf{K} + \mathbf{R}\mathbf{R}^T)^{-1}, & (\mathbf{P}\mathbf{K} + \mathbf{R}\mathbf{R}^T)^{-1} \mathbf{P}, & \mathbf{P}(\mathbf{P}\mathbf{K} + \mathbf{R}\mathbf{R}^T)^{-1} \mathbf{P}, \\
& \mathbf{P}(\mathbf{K}\mathbf{P} + \mathbf{R}\mathbf{R}^T)^{-1}, & (\mathbf{K}\mathbf{P} + \mathbf{R}\mathbf{R}^T)^{-1} \mathbf{P}, & \mathbf{P}(\mathbf{K}\mathbf{P} + \mathbf{R}\mathbf{R}^T)^{-1} \mathbf{P}, \\
& \mathbf{P}(\mathbf{P}\mathbf{K}\mathbf{P} + \mathbf{R}\mathbf{R}^T)^{-1}, & (\mathbf{P}\mathbf{K}\mathbf{P} + \mathbf{R}\mathbf{R}^T)^{-1} \mathbf{P}, & \mathbf{P}(\mathbf{P}\mathbf{K}\mathbf{P} + \mathbf{R}\mathbf{R}^T)^{-1} \mathbf{P}.
\end{aligned} \tag{17}$$

These are equivalent in exact arithmetic if \mathbf{K} is ‘‘RBM clean’’ in the sense that $\mathbf{K}\mathbf{R} = \mathbf{0}$. If \mathbf{K} is, however, ‘‘polluted’’ in the sense that $\mathbf{K}\mathbf{R} \neq \mathbf{0}$ the expressions (17) will generally yield different results for \mathbf{F} . Furthermore, matrices given by the formulas in the second and third rows may not be symmetric. If \mathbf{K} is polluted, the last row formulas are recommended, because the *filtered stiffness* $\mathbf{P}\mathbf{K}\mathbf{P}$ is guaranteed to be both symmetric and clean.

Similarly, if \mathbf{F} is known, \mathbf{K} may be computed from one of the 12 formulas

$$\begin{aligned}
& \mathbf{P}(\mathbf{F} + \mathbf{R}\mathbf{R}^T)^{-1}, & (\mathbf{F} + \mathbf{R}\mathbf{R}^T)^{-1} \mathbf{P}, & \mathbf{P}(\mathbf{F} + \mathbf{R}\mathbf{R}^T)^{-1} \mathbf{P}, \\
& \mathbf{P}(\mathbf{P}\mathbf{F} + \mathbf{R}\mathbf{R}^T)^{-1}, & (\mathbf{P}\mathbf{F} + \mathbf{R}\mathbf{R}^T)^{-1} \mathbf{P}, & \mathbf{P}(\mathbf{P}\mathbf{F} + \mathbf{R}\mathbf{R}^T)^{-1} \mathbf{P}, \\
& \mathbf{P}(\mathbf{F}\mathbf{P} + \mathbf{R}\mathbf{R}^T)^{-1}, & (\mathbf{F}\mathbf{P} + \mathbf{R}\mathbf{R}^T)^{-1} \mathbf{P}, & \mathbf{P}(\mathbf{F}\mathbf{P} + \mathbf{R}\mathbf{R}^T)^{-1} \mathbf{P}, \\
& \mathbf{P}(\mathbf{P}\mathbf{F}\mathbf{P} + \mathbf{R}\mathbf{R}^T)^{-1}, & (\mathbf{P}\mathbf{F}\mathbf{P} + \mathbf{R}\mathbf{R}^T)^{-1} \mathbf{P}, & \mathbf{P}(\mathbf{P}\mathbf{F}\mathbf{P} + \mathbf{R}\mathbf{R}^T)^{-1} \mathbf{P},
\end{aligned} \tag{18}$$

which are equivalent if $\mathbf{F}\mathbf{R} = \mathbf{0}$.

3.4 Forming the RBM Matrix

If the substructure is free-free and has no spurious modes, the construction of \mathbf{R} by geometric arguments is straightforward. This is illustrated here for the two-dimensional case of Figure 1. To facilitate satisfaction of orthogonality, it is convenient to place the x, y axes at the geometric mean of the N node locations of the substructure. Three independent RBMs are the x translation $u_x = 1, u_y = 0$, the y translation $u_x = 0, u_y = 1$ and the z rotation $u_x = -y, u_y = x$. Evaluation at the nodes gives

$$\mathbf{R}^T = \begin{bmatrix} 1 & 0 & 1 & \dots & 0 \\ 0 & 1 & 0 & \dots & 1 \\ -y_1 & x_1 & -y_2 & \dots & x_N \end{bmatrix}. \tag{19}$$

The columns of this \mathbf{R} are mutually orthogonal by construction. All that remains is to normalize them through division by $N^{1/2}$, $N^{1/2}$ and $[\sum_i (x_i^2 + y_i^2)]^{1/2}$, respectively. The three-dimensional case is equally straightforward.

3.5 Reduction to Boundary Freedoms

The expressions of \mathbf{K} , \mathbf{F} and \mathbf{R} used in previous relations pertain to all degrees of freedom of the substructure. For some applications only the substructural boundary freedoms are involved, and the interior degrees of freedom are eliminated in some way. To effect this elimination it is convenient

to partition \mathbf{F} and \mathbf{K} as follows:

$$\mathbf{K} = \begin{bmatrix} \mathbf{K}_{bb} & \mathbf{K}_{bi} \\ \mathbf{K}_{ib} & \mathbf{K}_{ii} \end{bmatrix}, \quad \mathbf{F} = \begin{bmatrix} \mathbf{F}_{bb} & \mathbf{F}_{bi} \\ \mathbf{F}_{ib} & \mathbf{F}_{ii} \end{bmatrix}, \quad \mathbf{R} = \begin{bmatrix} \mathbf{R}_b \\ \mathbf{R}_i \end{bmatrix}, \quad (20)$$

In a free-free substructure, all interior degrees of freedoms are unconstrained (that is, nodal forces are known). Reduction to the boundary by a static condensation produces the matrices

$$\mathbf{K}_b = \mathbf{K}_{bb} - \mathbf{K}_{bi} \mathbf{K}_{ii}^{-1} \mathbf{K}_{ib}, \quad \mathbf{F}_b = \mathbf{F}_{bb} \quad (21)$$

\mathbf{K}_b is the condensed stiffness matrix, also known as a Schur complement in the mathematical literature. Note that the reduction to a boundary flexibility \mathbf{F}_b is trivial.

Denote the boundary projector by $\mathbf{P}_b = \mathbf{I} - \mathbf{R}_b(\mathbf{R}_b \mathbf{R}_b)^{-1} \mathbf{R}_b^T$. Note that \mathbf{R}_b is not generally orthonormal, and consequently the scaling by $(\mathbf{R}_b \mathbf{R}_b)^{-1}$ must be retained. Then matrices (21) are related by the expressions (17) and (18), in which all matrices pertain to the boundary freedoms only. For example

$$\mathbf{F}_b = \mathbf{P}_b (\mathbf{P}_b \mathbf{K}_b \mathbf{P}_b + \mathbf{R}_b (\mathbf{R}_b \mathbf{R}_b)^{-1} \mathbf{R}_b^T)^{-1}, \quad \mathbf{K}_b = \mathbf{P}_b (\mathbf{P}_b \mathbf{F}_b \mathbf{P}_b + \mathbf{R}_b (\mathbf{R}_b \mathbf{R}_b)^{-1} \mathbf{R}_b^T)^{-1}. \quad (22)$$

The second of (22) is of interest when \mathbf{F}_b is directly available; e.g. from experimental data in system identification problems.

3.6 Rank Change in Nonlinear Analysis

In geometrically nonlinear Lagrangian analysis a common occurrence is the loss of rotational rigid body modes, which results in a gain of rank of \mathbf{K} with respect to the linear case. This is illustrated in Example 3 below. In plasticity analysis a loss of rank due to plastic flow mechanisms may occur. In either event the null space of \mathbf{K} has to be appropriately adjusted.

4. UNSYMMETRIC MATRICES

Unsymmetric tangent stiffness matrices occur in finite element nonlinear analysis if one or more of the following effects are modeled: (1) co-rotational kinematics, (2) follower load terms, and (3) non-associative constitutive laws. In this case not only is the free-free flexibility unsymmetric but the pseudo-inverse and sg-inverse generally differ.

Assume \mathbf{K} is now real unsymmetric real but nondefective. Let \mathbf{R} and \mathbf{Q} span the null space of columns and rows, respectively, of \mathbf{K} so that $\mathbf{K}\mathbf{R} = \mathbf{0}$ and $\mathbf{Q}^T \mathbf{K} = \mathbf{0}$. The columns of \mathbf{R} retain the meaning of rigid body modes, but \mathbf{Q} has no physical significance and must be computed separately. These matrices may be assembled from the null left eigenvectors of \mathbf{K} and \mathbf{K}^T , respectively, and are bi-orthonormalized so that $\mathbf{Q}^T \mathbf{R} = \mathbf{R}^T \mathbf{Q} = \mathbf{I}$. Define the column and row projectors

$$\mathbf{P} = \mathbf{I} - \mathbf{R}\mathbf{Q}^T, \quad \mathbf{P}^T = \mathbf{I} - \mathbf{Q}\mathbf{R}^T, \quad (23)$$

so that $\mathbf{K}\mathbf{P} = \mathbf{K}$ and $\mathbf{K}^T \mathbf{P}^T = \mathbf{K}^T$.

Two possible choices for the free-free flexibility \mathbf{F} are the pseudo-inverse $\mathbf{F} = \mathbf{K}^+$, and the sg-inverse \mathbf{K}^\dagger . For the pseudo-inverse choice the following 12 formulas apply:

$$\begin{aligned}
& (\mathbf{P}^T \mathbf{K} + \mathbf{Q} \mathbf{R}^T)^{-1} \mathbf{P}^T, & (\mathbf{P}^T \mathbf{K} \mathbf{P} + \mathbf{Q} \mathbf{R}^T)^{-1} \mathbf{P}^T, & (\mathbf{P}^T \mathbf{K} \mathbf{P}^T + \mathbf{Q} \mathbf{R}^T)^{-1} \mathbf{P}, \\
& \mathbf{P}^T (\mathbf{K} \mathbf{P}^T + \mathbf{Q} \mathbf{R}^T)^{-1}, & \mathbf{P}^T (\mathbf{K} \mathbf{P}^T + \mathbf{Q} \mathbf{R}^T)^{-1} \mathbf{P}^T, & \mathbf{P}^T (\mathbf{P} \mathbf{K} \mathbf{P}^T + \mathbf{Q} \mathbf{R}^T)^{-1}, \\
& \mathbf{P}^T (\mathbf{P} \mathbf{K} \mathbf{P}^T + \mathbf{Q} \mathbf{R}^T)^{-1} \mathbf{P}^T, & \mathbf{P}^T (\mathbf{P}^T \mathbf{K} + \mathbf{Q} \mathbf{R}^T)^{-1} \mathbf{P}, & \mathbf{P}^T (\mathbf{P}^T \mathbf{K} \mathbf{P} + \mathbf{Q} \mathbf{R}^T)^{-1} \mathbf{P}^T, \\
& \mathbf{P}^T (\mathbf{P}^T \mathbf{K} \mathbf{P}^T + \mathbf{R} \mathbf{Q}^T)^{-1} \mathbf{P}^T, & \mathbf{P}^T (\mathbf{P}^T \mathbf{K} \mathbf{P}^T + \mathbf{Q} \mathbf{R}^T)^{-1}, & \mathbf{P}^T (\mathbf{P}^T \mathbf{K} \mathbf{P}^T + \mathbf{Q} \mathbf{R}^T)^{-1} \mathbf{P}^T.
\end{aligned} \tag{24}$$

For the sg-inverse choice $\mathbf{F} = \mathbf{K}^\dagger$ the following 16 expressions apply:

$$\begin{aligned}
& \mathbf{P}(\mathbf{K} + \mathbf{R} \mathbf{Q}^T)^{-1}, & (\mathbf{K} + \mathbf{R} \mathbf{Q}^T)^{-1} \mathbf{P}, & \mathbf{P}(\mathbf{K} + \mathbf{R} \mathbf{Q}^T)^{-1} \mathbf{P}, \\
& \mathbf{P}(\mathbf{P} \mathbf{K} + \mathbf{R} \mathbf{Q}^T)^{-1}, & (\mathbf{P} \mathbf{K} + \mathbf{R} \mathbf{Q}^T)^{-1} \mathbf{P}, & \mathbf{P}(\mathbf{P} \mathbf{K} + \mathbf{R} \mathbf{Q}^T)^{-1} \mathbf{P}, \\
& \mathbf{P}(\mathbf{K} \mathbf{P} + \mathbf{R} \mathbf{Q}^T)^{-1}, & (\mathbf{K} \mathbf{P} + \mathbf{R} \mathbf{Q}^T)^{-1} \mathbf{P}, & \mathbf{P}(\mathbf{K} \mathbf{P} + \mathbf{R} \mathbf{Q}^T)^{-1} \mathbf{P}, \\
& \mathbf{P}(\mathbf{P} \mathbf{K} \mathbf{P} + \mathbf{R} \mathbf{Q}^T)^{-1}, & (\mathbf{P} \mathbf{K} \mathbf{P} + \mathbf{R} \mathbf{Q}^T)^{-1} \mathbf{P}, & \mathbf{P}(\mathbf{P} \mathbf{K} \mathbf{P} + \mathbf{R} \mathbf{Q}^T)^{-1} \mathbf{P}, \\
& \mathbf{P}(\mathbf{K} + \mathbf{Q} \mathbf{R}^T)^{-1} \mathbf{P}, & \mathbf{P}(\mathbf{K} \mathbf{P} + \mathbf{Q} \mathbf{R}^T)^{-1} \mathbf{P}, & \mathbf{P}(\mathbf{K} \mathbf{P}^T + \mathbf{Q} \mathbf{R}^T)^{-1} \mathbf{P}, \\
& \mathbf{P}(\mathbf{P} \mathbf{K} + \mathbf{Q} \mathbf{R}^T)^{-1} \mathbf{P}, & \mathbf{P}(\mathbf{P} \mathbf{K} \mathbf{P} + \mathbf{Q} \mathbf{R}^T)^{-1} \mathbf{P}, & \mathbf{P}(\mathbf{P} \mathbf{K} \mathbf{P}^T + \mathbf{Q} \mathbf{R}^T)^{-1} \mathbf{P}, \\
& \mathbf{P}(\mathbf{P} \mathbf{K} + \mathbf{Q} \mathbf{R}^T)^{-1} \mathbf{P}, & \mathbf{P}(\mathbf{P}^T \mathbf{K} \mathbf{P} + \mathbf{Q} \mathbf{R}^T)^{-1} \mathbf{P}.
\end{aligned} \tag{25}$$

Transposing (24) yields 12 expressions for $(\mathbf{K}^T)^+$ and transposing (25) yields 16 expressions for $(\mathbf{K}^T)^\dagger$. All of the expressions are equivalent in exact arithmetic when $\mathbf{K} \mathbf{R} = \mathbf{0}$ and $\mathbf{K}^T \mathbf{Q} = \mathbf{0}$. The question of which choice of generalized inverse is more appropriate depends on the target application. In applications in which the spectrum of \mathbf{K} is important, such as dynamic instability, the sg-inverse is obviously preferable.

5. EXAMPLES

The three following examples pertain to simple individual elements, in which case the free-free flexibility can be computed analytically from the definition formulas. More complicated elements or substructures formed by multiple elements require numeric work.

5.1 Example 1: Linear 1D Bar Element

For the one-dimensional 2-node bar element illustrated in Figure 2(a) direct application of the definition (9) yields

$$\begin{aligned}
\mathbf{K} &= k \begin{bmatrix} 1 & -1 \\ -1 & 1 \end{bmatrix}, & \mathbf{R} &= \frac{1}{\sqrt{2}} \begin{bmatrix} 1 \\ 1 \end{bmatrix}, & \mathbf{P} &= \frac{1}{2} \begin{bmatrix} 1 & -1 \\ -1 & 1 \end{bmatrix} = \frac{1}{2k} \mathbf{K}, \\
\mathbf{F} &= \mathbf{P}(\mathbf{K} + \mathbf{R} \mathbf{R}^T)^{-1} = \frac{1}{4k} \begin{bmatrix} 1 & -1 \\ -1 & 1 \end{bmatrix} = \frac{1}{4k^2} \mathbf{K}.
\end{aligned} \tag{26}$$

where $k = EA/L$ is the axial (equivalent spring) stiffness. It can be verified that the result $\mathbf{K} = 4k^2 \mathbf{F}$ also holds for two-node linear bar elements moving in two and three dimensions. Robinson [3] has given an equivalent flexibility expression starting from an axial assumed-stress element.

For this element one may also use the definition of pseudo-inverse from the spectral decomposition

$$\mathbf{K} = \mathbf{Q}^T (2k) \mathbf{Q}, \quad \mathbf{Q} = \frac{1}{\sqrt{2}} \begin{bmatrix} -1 \\ 1 \end{bmatrix}, \quad \mathbf{F} = \mathbf{Q}^T \frac{1}{2k} \mathbf{Q} = \frac{1}{4k^2} \mathbf{Q}^T (2k) \mathbf{Q} = \frac{1}{4k^2} \mathbf{K}, \quad (27)$$

in which $\mathbf{Q}^T \mathbf{Q} = \mathbf{I}$. But this becomes unwieldy for more complex elements.

5.2 Example 2: Linear Plane Beam Element

For the 2-node, 4-dof, Bernoulli-Euler prismatic plane beam element shown in Figure 2(b):

$$\mathbf{K} = \frac{EI}{L^3} \begin{bmatrix} 12 & 6L & -12 & 6L \\ 6L & 4L^2 & -6L & 2L^2 \\ -12 & -6L & 12 & -6L \\ 6L & 2L^2 & -6L & 4L^2 \end{bmatrix}, \quad \mathbf{R} = \begin{bmatrix} 1/\sqrt{2} & -\frac{1}{2}L/\sqrt{2 + \frac{1}{2}L^2} \\ 0 & 1/\sqrt{2 + \frac{1}{2}L^2} \\ 1/\sqrt{2} & \frac{1}{2}L/\sqrt{2 + \frac{1}{2}L^2} \\ 0 & 1/\sqrt{2 + \frac{1}{2}L^2} \end{bmatrix}, \quad (28)$$

$$\mathbf{F} = F_b \begin{bmatrix} L^2 & \frac{1}{2}L^3 & -L^2 & \frac{1}{2}L^3 \\ \frac{1}{2}L^3 & 12 + 6L^2 + L^4 & -\frac{1}{2}L^3 & -12 - 6L^2 - \frac{1}{2}L^4 \\ -L^2 & -\frac{1}{2}L^3 & L^2 & -\frac{1}{2}L^3 \\ \frac{1}{2}L^3 & -12 - 6L^2 - \frac{1}{2}L^4 & -\frac{1}{2}L^3 & 12 + 6L^2 + L^4 \end{bmatrix}$$

where $F_b = L(4 + L^2)^{-2}/(3EI)$. Note that entries of \mathbf{F} are not dimensionally homogeneous. This is a consequence of the unavoidable mixture of translational and rotational nodal displacements in the orthonormalization of \mathbf{R} .

5.3 Example 3: Unsymmetric Bar Stiffness

The last example deals with a geometrically nonlinear 2-node bar element moving in the $x - y$ plane under follower lateral pressure q , as illustrated in Figure 2(c). The bar is under a prestress axial force P . In a Total Lagrangian description, the tangent stiffness matrix referred to the longitudinal bar axis is

$$\mathbf{K} = k_m \begin{bmatrix} 1 & 0 & -1 & 0 \\ 0 & 0 & 0 & 0 \\ -1 & 0 & 1 & 0 \\ 0 & 0 & 0 & 0 \end{bmatrix} + k_g \begin{bmatrix} 1 & 0 & -1 & 0 \\ 0 & 1 & 0 & -1 \\ -1 & 0 & 1 & 0 \\ 0 & -1 & 0 & 1 \end{bmatrix} + k_f \begin{bmatrix} 0 & -1 & 0 & 1 \\ 1 & 0 & -1 & 0 \\ 0 & -1 & 0 & 1 \\ 1 & 0 & -1 & 0 \end{bmatrix} \quad (29)$$

where $k_m = EA/L$, $k_g = P/L$ and $k_f = \frac{1}{2}q$. The matrix is symmetric if $q = 0$. It has rank 2 if $k_g \neq 0$ or $k_f \neq 0$ because the rotational RBM is then lost. Hence \mathbf{R} and \mathbf{Q} have two columns:

$$\mathbf{R}^T = \frac{1}{\sqrt{2}} \begin{bmatrix} 1 & 0 & 1 & 0 \\ 0 & 1 & 0 & 1 \end{bmatrix}, \quad \mathbf{Q}^T = \frac{1}{\sqrt{2}} \begin{bmatrix} -\frac{k_f}{k_m + k_g} & 1 & \frac{k_f}{k_m + k_g} & 1 \\ 1 & -\frac{k_f}{k_m + k_g} & 1 & \frac{k_f}{k_m + k_g} \end{bmatrix} \quad (30)$$

The pseudo-inverse flexibility is

$$\mathbf{F} = \mathbf{K}^+ = \frac{1}{4} \begin{bmatrix} a & b & -a & b \\ c & d & c & -d \\ -a & -b & a & -b \\ -c & -d & -c & d \end{bmatrix} \quad (31)$$

where $a = (k_m + k_g)/(k_f^2 + k_g^2 + 2k_g k_m + k_m^2)$, $b = k_f/(k_f^2 + k_g^2 + 2k_g k_m + k_m^2)$, $c = -k_f/(k_f^2 + k_g^2)$ and $d = k_g/(k_f^2 + k_g^2)$.

The sg-inverse flexibility is

$$\mathbf{F} = \mathbf{K}^\dagger = \frac{1}{4} \begin{bmatrix} a & b & -a & b \\ c & d & -c & -d \\ -a & -b & a & b \\ c & -d & -c & d \end{bmatrix} \quad (32)$$

where $a = 1/(k_m + k_g)$, $b = k_f/k_g^2$, $c = k_f/(k_m + k_g)^2$, $d = 1/k_g$. Matrices (32) and (31) coalesce if $k_f = 0$. If $k_g = k_f = 0$ both expressions “blow up” and do not reduce to that of a linear bar because the rank of \mathbf{K} changes from 2 to 1 as the rotational RBM becomes active.

6. CONCLUDING REMARKS

We have introduced structural free-free flexibility matrices \mathbf{F} as duals of the well known free-free stiffness matrix \mathbf{K} . Although \mathbf{K} and \mathbf{F} are generalized inverses of each other, the formulas presented here use only ordinary inverses and projectors, and hence bypass the use of an expensive eigensystem analysis. This avoidance comes at the price of the separate construction of the matrix of rigid body modes \mathbf{R} (and of \mathbf{Q} in the unsymmetric case). For free-free substructures the construction of \mathbf{R} may be carried out geometrically.

The main applications of the free-free flexibility to date has been in substructural-based solution algorithms typified by the Direct Flexibility Method (DFM) described by Felippa and Park [4]. The DFM may be viewed in a certain sense as a dual of the Direct Stiffness Method, and belongs to a wider class of flexibility-based methods [5]. These methods have proven useful in special applications, notably massively parallel processing and system identification [6–9].

The present exposition has illustrated the computation of \mathbf{F} using individual finite elements, in which case symbolic computations are possible. In practical applications of the DFM, however, the free-free flexibility of substructures containing hundreds or thousands of degrees of freedom is usually required. The efficient numerical computation of \mathbf{F} for such cases is dealt with in a separate article [7].

Acknowledgments. — The present work has been supported by the National Science Foundation under NSF/HPCC Grant ASC-9217394 and by Sandia National Laboratories under Contracts AS-5666 and AS-9991.

REFERENCES

1. G. W. Stewart and J. Sun, *Matrix Perturbation Theory*, Academic Press, New York, 1990.
2. C. R. Rao and S. K. Mitra, *Generalized Inverse of Matrices and its Applications*, Wiley, New York, 1971.
3. J. Robinson, Automatic extraction of rigid body modes from stress and strain elements, in *Variational Methods in Engineering*, ed. by C. A. Brebbia and H. Tottenham, University of Southampton Press, Southampton, U.K., Part 4, 73–92, 1973.
4. C. A. Felippa and K. C. Park, A direct flexibility method, *Computer Methods in Applied Mechanics and Engineering*, **149**, 319–337, 1997.
5. K. C. Park and C. A. Felippa, A variational framework for solution method developments in structural mechanics, Center for Aerospace Structures, Report No. CU-CAS-96-22, University of Colorado, 1996; to appear in *Journal of Applied Mechanics*.
6. K. C. Park, M. R. Justino Filho and C. A. Felippa, An algebraically partitioned FETI method for parallel structural analysis: algorithm description, *International Journal for Numerical Methods in Engineering*, **40**, 2717-2737, 1997.
7. M. R. Justino Filho, K. C. Park and C. A. Felippa, An algebraically partitioned FETI method for parallel structural analysis: performance evaluation, *International Journal for Numerical Methods in Engineering*, **40**, 2739–2758, 1997.
8. K. C. Park and K. F. Alvin, Extraction of substructural flexibility from measured global modes and mode shapes, *Proc. 1996 AIAA SDM Conference*, Paper No. AIAA 96-1297, Salt Lake City, Utah, April 1996, also *AIAA Journal*, Volume 35, Number 7, 1997, 1187-1194
9. W. S. Hwang, K. W. Belvin, and K. C. Park, Design of complex vibration control systems based on spatial energy transmission patterns, *Proc. 1995 AIAA SDM Conference*, Paper No. AIAA 95-1381, April 18-21 1995, New Orleans, LA.; to appear in *AIAA Journal of Guidance, Control and Dynamics*.

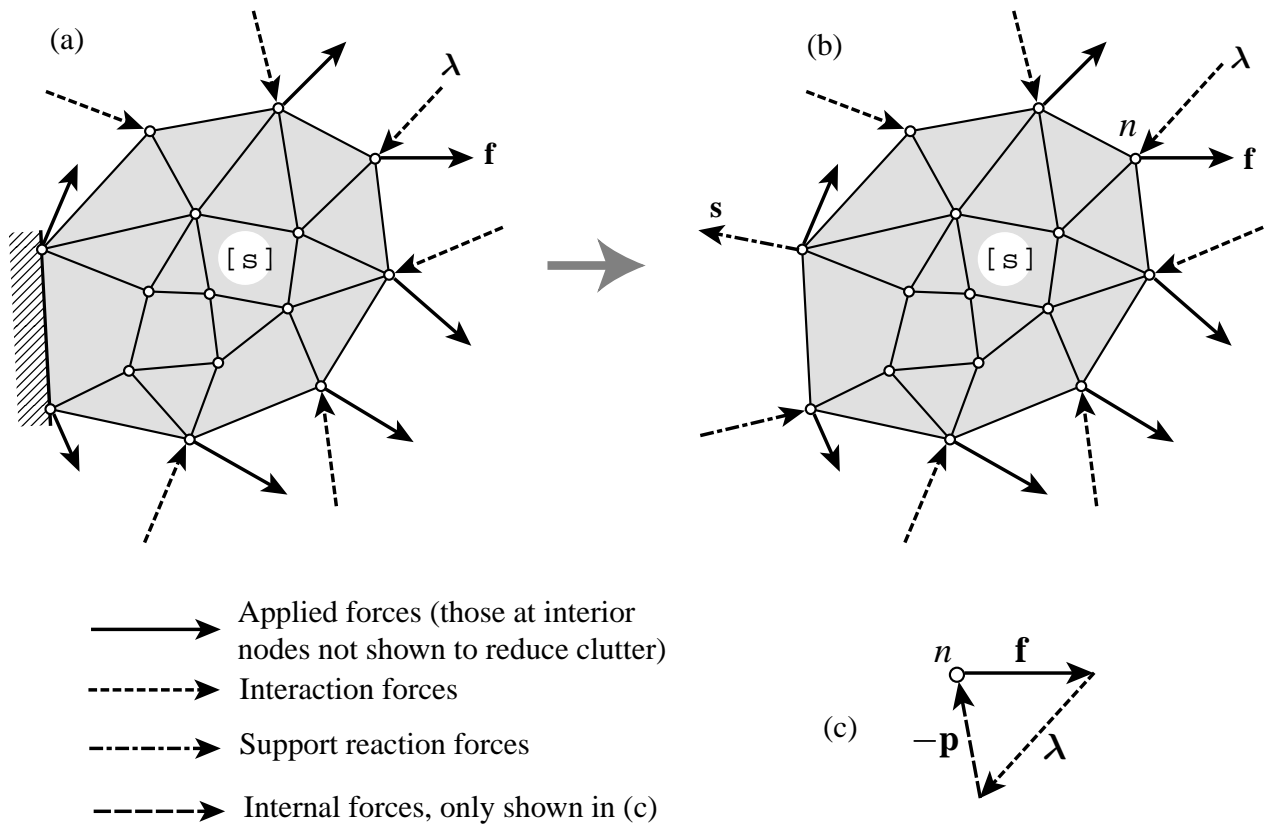

Figure 1. A generic substructure $[s]$ and the force systems acting on it. The top figures illustrate the conversion from a partly or fully supported configuration (a) to a free-free configuration (b) by replacing supports by reaction forces. The self-equilibrium of a free-body node n is shown in (c).

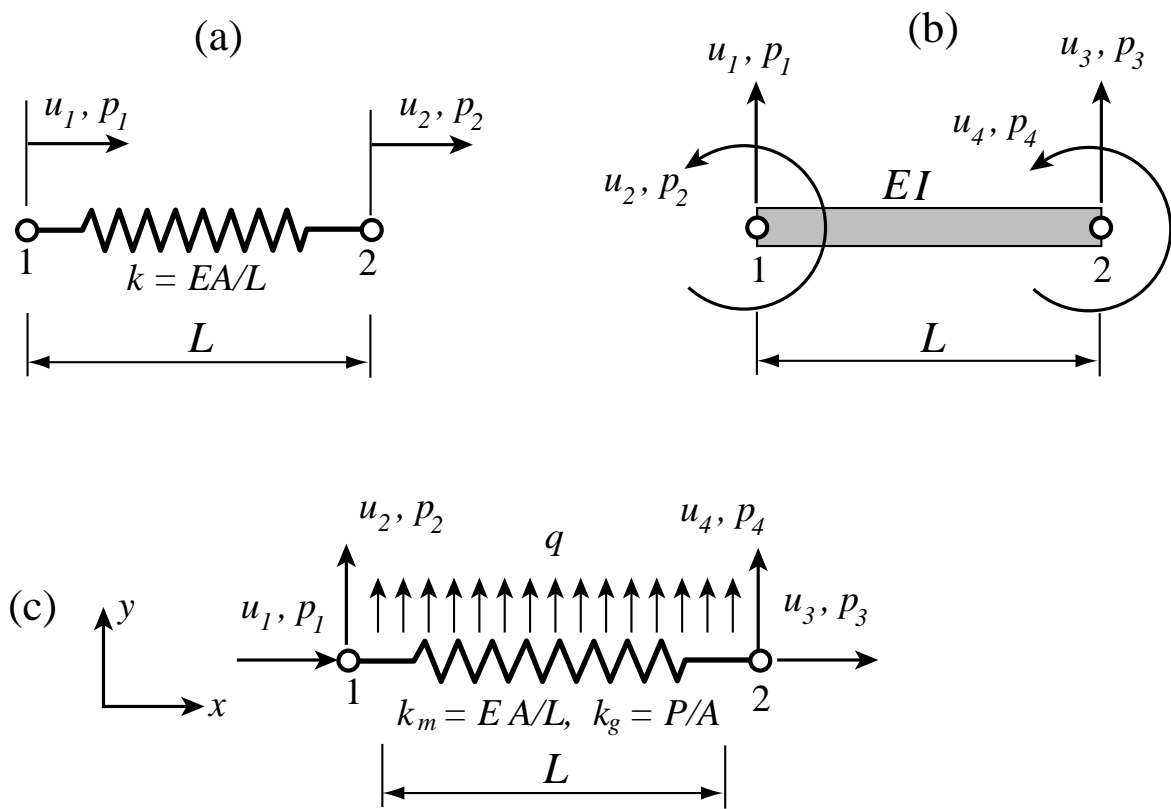

Figure 2. Bar and beam elements for Examples 1-3.

FIGURE CAPTIONS

Figure 1. A generic substructure $[s]$ and the force systems acting on it. The top figures illustrate the conversion from a partly or fully supported configuration (a) to a free-free configuration (b) by replacing supports by reaction forces. The self-equilibrium of a free-body node n is shown in (c).

Figure 2. Bar and beam elements for Examples 1-3.